

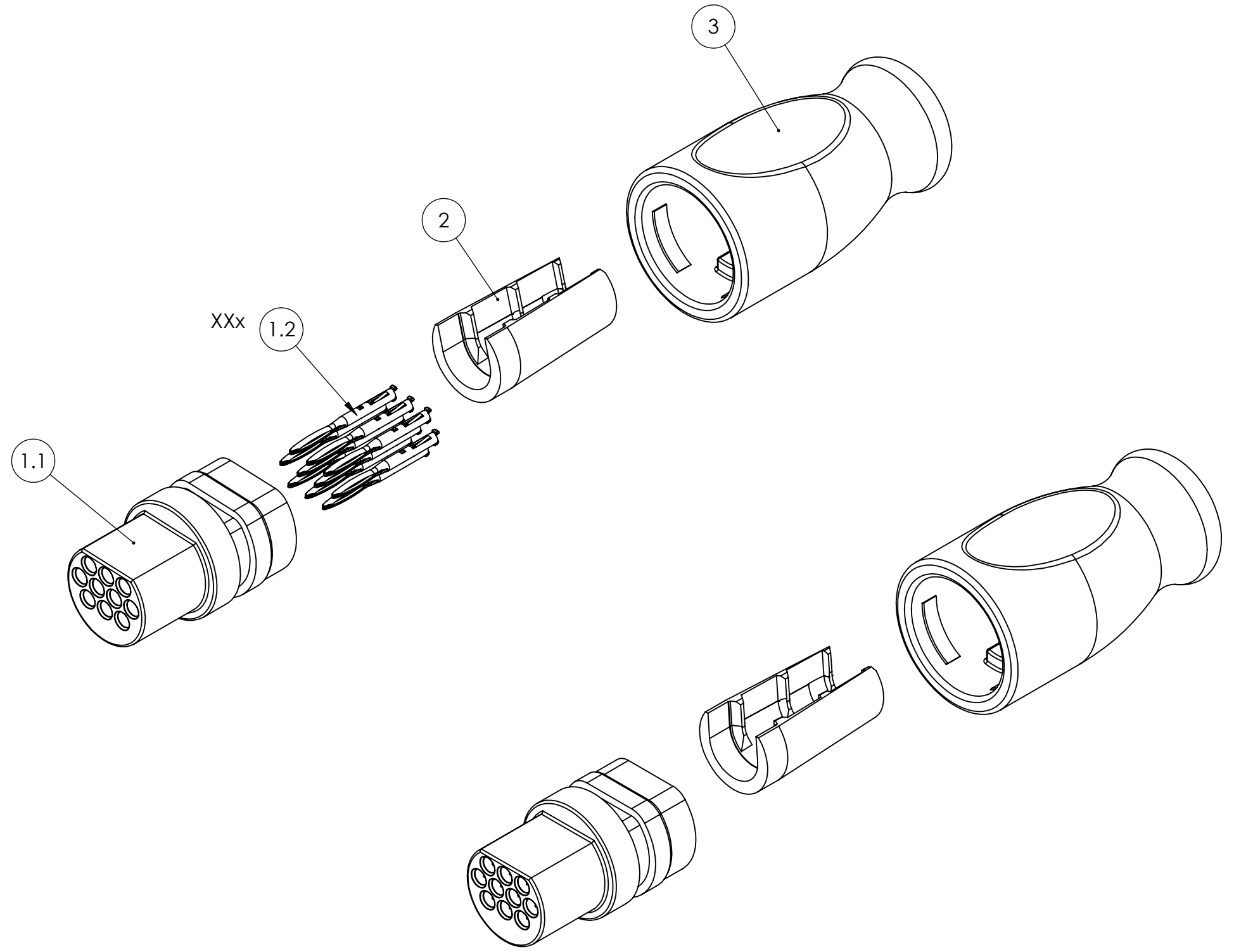

ITEM NO.	PART NUMBER	DESCRIPTION	QTY.
1	225-A005-XXX	NEUTRINO MALE HOUSIING ASSEMBLY	1
1.1	225-PT002-X	NEUTRINO MALE HOUSING	1
1.2	0437	MALE PIN	XX
2	101-PT011	STRAIN RELIEF	1
3	225-PT003-XXXX	SLIP ON BOOT	1

REV.	DESCRIPTION OF CHANGES	REL. BY	ECO#	REL. DATE
01	INITIAL RELEASE	KK	7747	1/12/2026

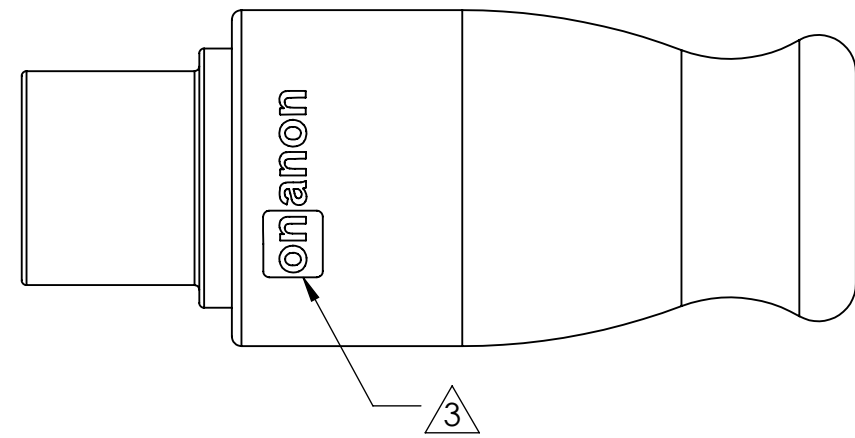

NOTES (UNLESS OTHERWISE SPECIFIED)

- ASSEMBLY SHALL COMPLY WITH THE RESTRICTIONS OF THE USE OF HAZARDOUS SUBSTANCES (ROHS) SET FORTH IN EU DIRECTIVES 2011/65/EU AND 2015/863/EU.
- ASSEMBLY SHALL COMPLY WITH REGISTRATION EVALUATION AUTHORIZATION RESTRICTIONS OF CHEMICALS (REACH) SET FORTH IN EU DIRECTIVE 1907/2006/EU.
-  LASER MARK ONANON LOGO
- PACKAGING:
  - PROVIDE ADEQUATE PACKAGING TO PREVENT DAMAGES DURING SHIPPING AND HANDLING
  - DO NOT ASSEMBLE ITEM ①, ② AND ③ WITH EACH OTHER
- LABEL EACH PACKAGE WITH THE FOLLOWING INFORMATION:
  - PART NUMBER
  - PURCHASE ORDER NUMBER
  - MANUFACTURING DATE AND LOT NUMBER
  - QUANTITY PER PACKAGE
- CERTIFICATIONS OF CONFORMANCE:
  - MATERIAL CERTIFICATION
  - CERTIFICATION OF CONFORMANCE (TO INCLUDE PART#, LOT #, MANUFACTURING DATE, AND MATERIAL LOT #)

**PART NUMBER CONVENTION**

225-A006-**XXX** - **XXXX**



**NO. OF CONTACTS** (see pg 2)  
02, 04, 06, 08, 10

**PLUG COLOR**  
B – BLACK ; W – WHITE

**BOOT ID**  
065 =  $\varnothing$ 0.065" ; 085 =  $\varnothing$ 0.085"  
105 =  $\varnothing$ 0.105" ; 126 =  $\varnothing$ 0.126"  
150 =  $\varnothing$ 0.150"

**BOOT COLOR**  
B – BLACK      N – GREEN  
G – GREY      W – WHITE  
R – RED        U – BLUE  
Y – YELLOW

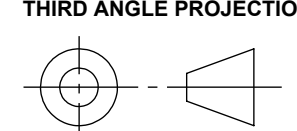
Contact Sales for Alternative Configurations

 THIRD ANGLE PROJECTION UNLESS OTHERWISE SPECIFIED ALL DIMENSIONS ARE IN INCHES [MM] STANDARD TOLERANCES .XX ±.010    .XXX ±.005    .XXXX ±.002    ANGLE ±2°    DIAMETER ±.002 SURFACE FINISH: (UNLESS OTHERWISE SPECIFIED) N/A	THIS DRAWING CONTAINS PROPRIETARY INFORMATION AND IS THE SOLE PROPERTY OF ONANON, INC. IT MAY NOT BE REPRODUCED, TRANSMITTED OR OTHERWISE DISCLOSED TO ANY OTHER PARTY WITHOUT WRITTEN CONSENT FROM ONANON, INC.		 an Amphenol company 720 SOUTH MILPITAS BLVD. MILPITAS, CA 95035 PHONE: (408) 262-8990 FAX: (408) 262-2901 WWW.ONANON.COM	
	DRAWN BY: K. KESHTGAR    DATE: 1/12/2026 CHECKED BY: M. BEAUPRE    DATE: 1/12/2026 APPROVED BY: E. RUCK    DATE: 1/12/2026 HTS CODE: 8536.69.4040	DRAWING TITLE: NEUTRINO MALE PLUG KIT		
SIZE: <b>C</b> PART NUMBER: 225-A006-XXX-XXXX REFERENCE:    SHEET SCALE 2:1    SHEET 1 OF 2		ONANON REV.: 01 CUST. REV.: -		

**PIN POPULATION GUIDE**  
SOLID MARKED LOCATIONS DESIGNATE POPULATED PIN LOCATIONS

**225-A006-02X-XXXX**  
REAR VIEW

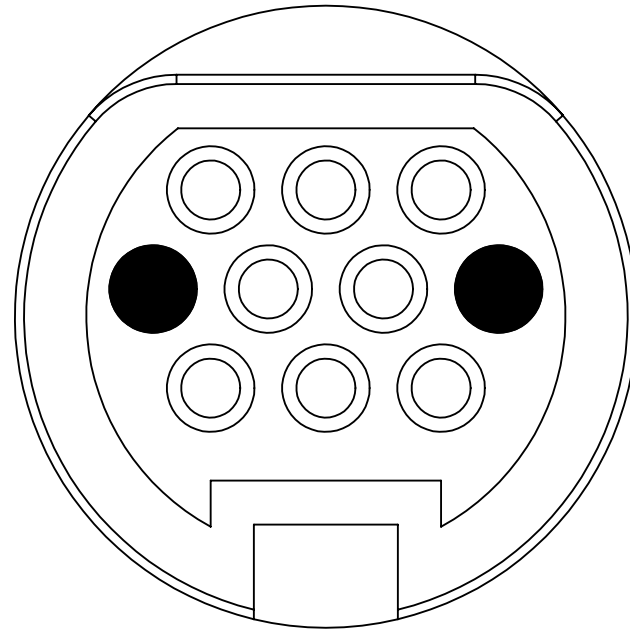

**225-A006-04X-XXXX**  
REAR VIEW

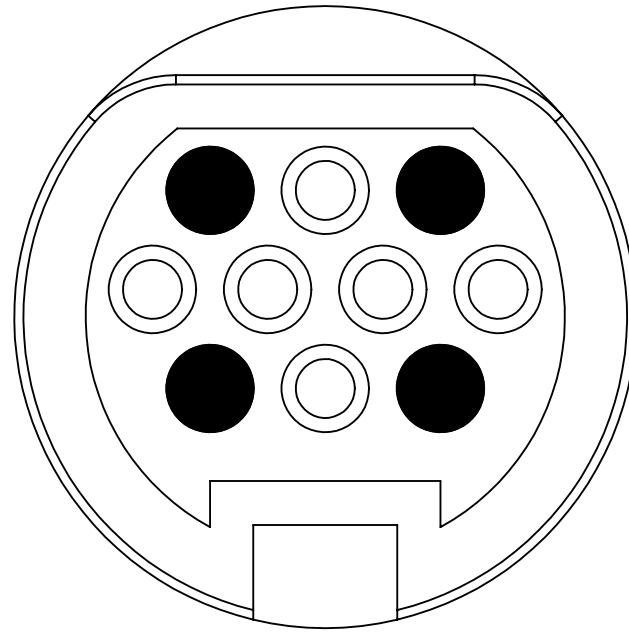

**225-A006-06X-XXXX**  
REAR VIEW

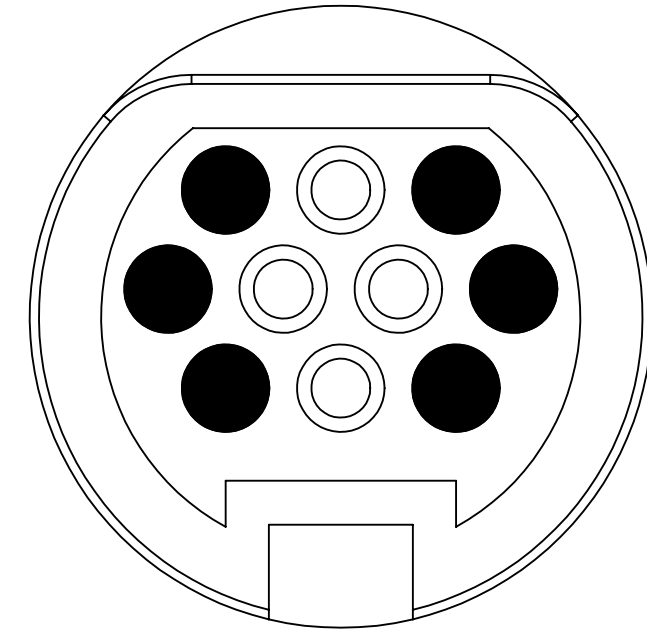

**225-A006-08X-XXXX**  
REAR VIEW

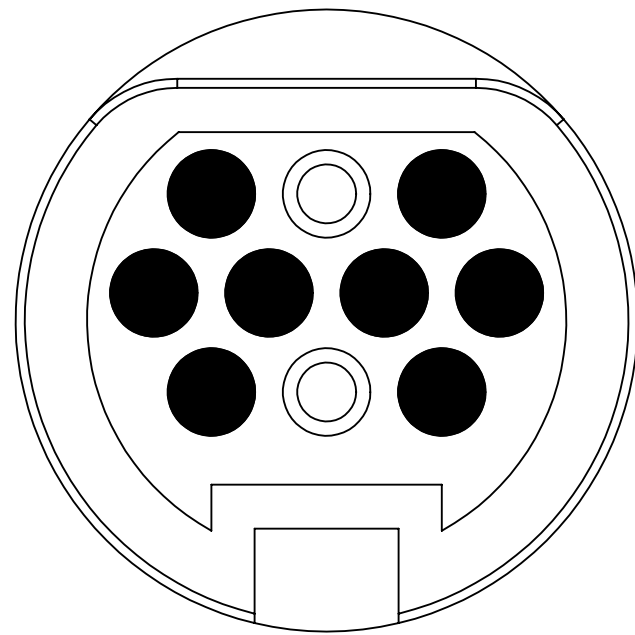

**225-A006-10X-XXXX**  
REAR VIEW

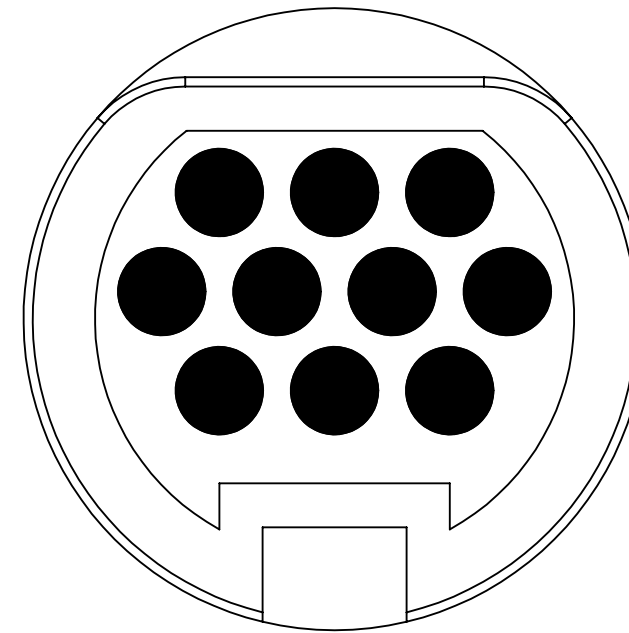

Onanon's *Neutrino*<sup>®</sup> is designed to significantly reduce weight and size while utilizing a Flex-Pin contact system for a rugged, reliable performance. Ideal for medical applications where "fit, form and function" is essential, such as handheld surgical devices, neuromodulation, sensors, and other hospital instrumentation.

- **10 pin capacity**
- **Compact size**
- **Favorably lightweight**
- **Customizable for reusable or disposable application**

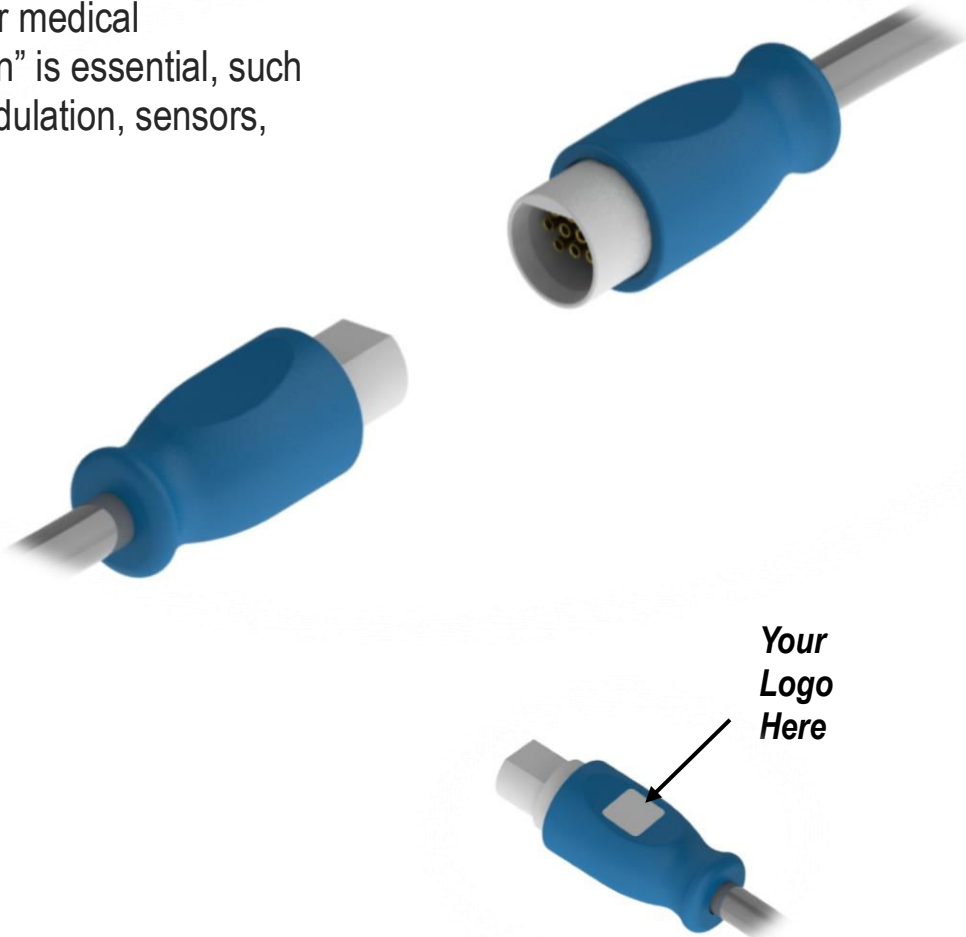

## Specifications

### Mechanical

**Mating Type:** Friction  
**Mating Cycles:**  
**Plug:** 5k min  
**Receptacle:** 6k min  
**Mating Forces:**  
**Insertion:** 4.0 lbf  
**Removal:** 2.7 lbf  
**Axial Tensile Force:**  
 13 lbf

### Electrical

**Operating Voltage:**  
 600M $\Omega$  @ 800 VDC  
 10M $\Omega$  @ 400 VAC  
**Operating Current:** 3A  
**End-End Resistance:**  
 < 1.5  $\Omega$

### Environmental

**Sterilizable:** Gamma  
**Chemical Resistance:** *Common or cleaning solvents*  
**Finger Safety:** IEC 60601-1  
**Storage & Operating Temp:**  
 0-46 °C  
**Weight:** 26g per cable assembly

### Compatibility

**Contacts:** 10 pins  
**Plug Cable Assembly**  
**Accepted Wire Gauges:** 30-32 AWG  
**Cable Jacket OD:** 0.12"  
**Contact Termination:** *Clip Contact*  
**In-Line Receptacle Cable Assembly**  
**Accepted Wire Gauges:** 30-32 AWG  
**Cable Jacket OD:** 0.12"  
**Contact Termination:** *Clip Contact*



## Lightweight

*Favorably lightweight for long procedural use*

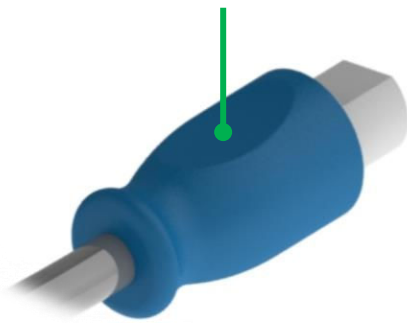

## Compact

*50 mil pin-pin spacing for a Micro fit design*

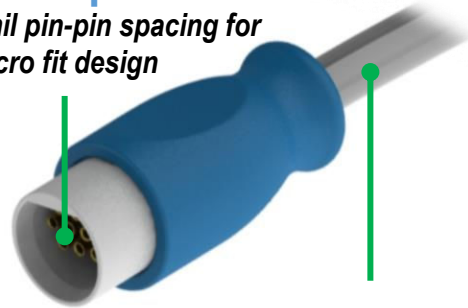

## EMI Shielding

*Shielded cable to combat the effects of EMI for delicate applications.*

## Materials & Assembly

### Male Plug Cable Assembly

**Plug Housing:** Thermoplastic Polyester

**Pins:** Gold Plated Brass Alloy

**Strain Relief:** Thermoplastic Polyester

**Slip-On Boot:** Polycarbonate

**Required Assembly:** Terminate flying leads to end-user device

### In-line Receptacle Cable Assembly

**Plug Housing:** Thermoplastic Polyester

**Pins:** Gold Plated Brass Alloy

**Strain Relief:** Thermoplastic Polyester

**Slip-On Boot:** Polycarbonate

**Required Assembly:** Terminate flying leads to end-user device

## Dimensions

### Male Plug Cable Assembly

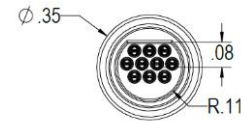
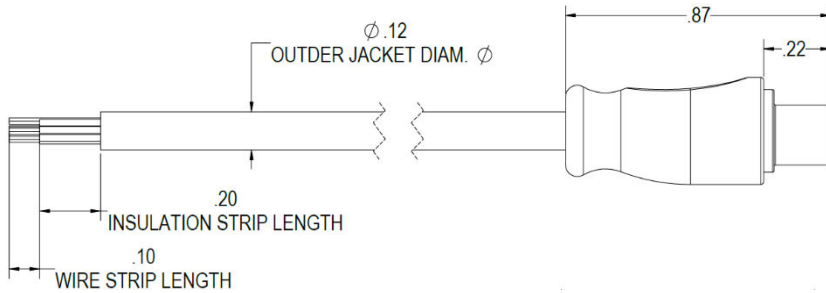

### In-Line Receptacle Cable Assembly

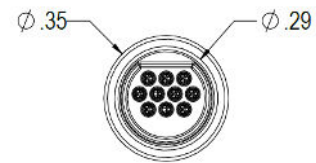
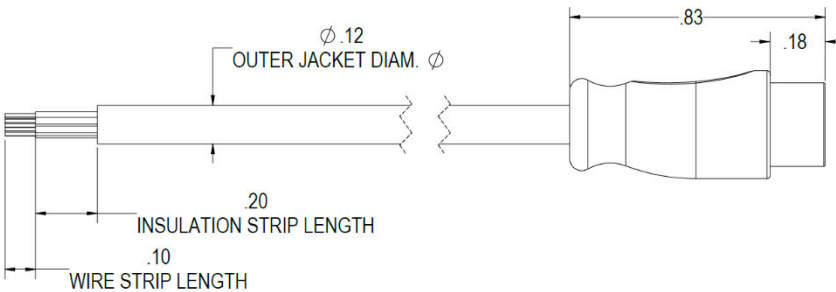

### Pin Out

Plug Housing  
(Rear View)

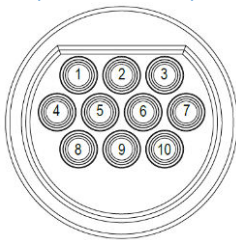

PIN NUMBER	CONDUCTOR COLOR	PIN NUMBER
1	BROWN	1
2	RED	2
3	ORANGE	3
4	YELLOW	4
5	GREEN	5
6	BLUE	6
7	VIOLET	7
8	GREY	8
9	DRAIN	9
10	WHITE	10

In-Line  
Receptacle  
(Rear View)

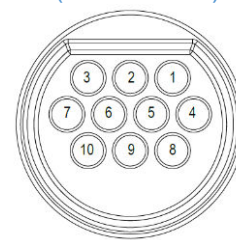

### Cable Specification

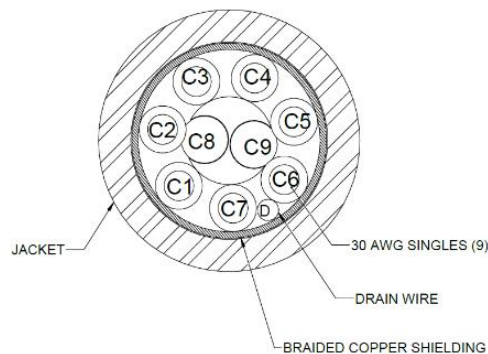

**Male Plug Cable  
Assembly**

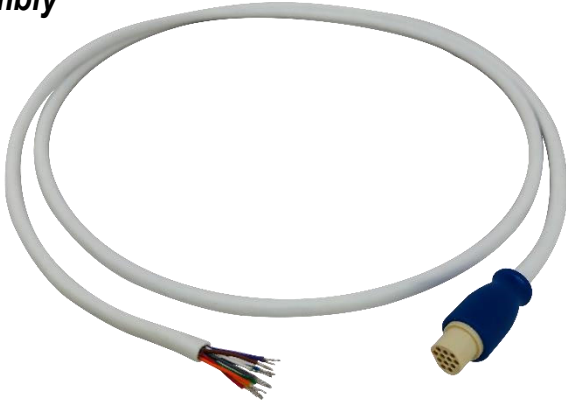

**In-Line Receptacle  
Cable Assembly**



## Configurations & Ordering

---

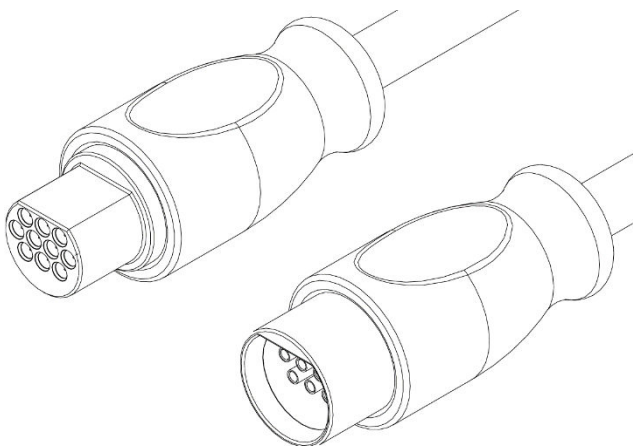

### Custom Options Available:

Reach out to our sales team about laser-engraved logos, personalized color options, high volume orders, and end-to-end custom cable assemblies, including our integrated SmartConnect™ capabilities.

#### Contact Us:

sales@onanon.com  
408-262-8990  
www.onanon.com  
720 S Milpitas Blvd.  
Milpitas, CA 95035



**2026 Edition**  
**Product Catalog**  
*Application Specific Interconnects*  
Medical · Industrial · Aerospace

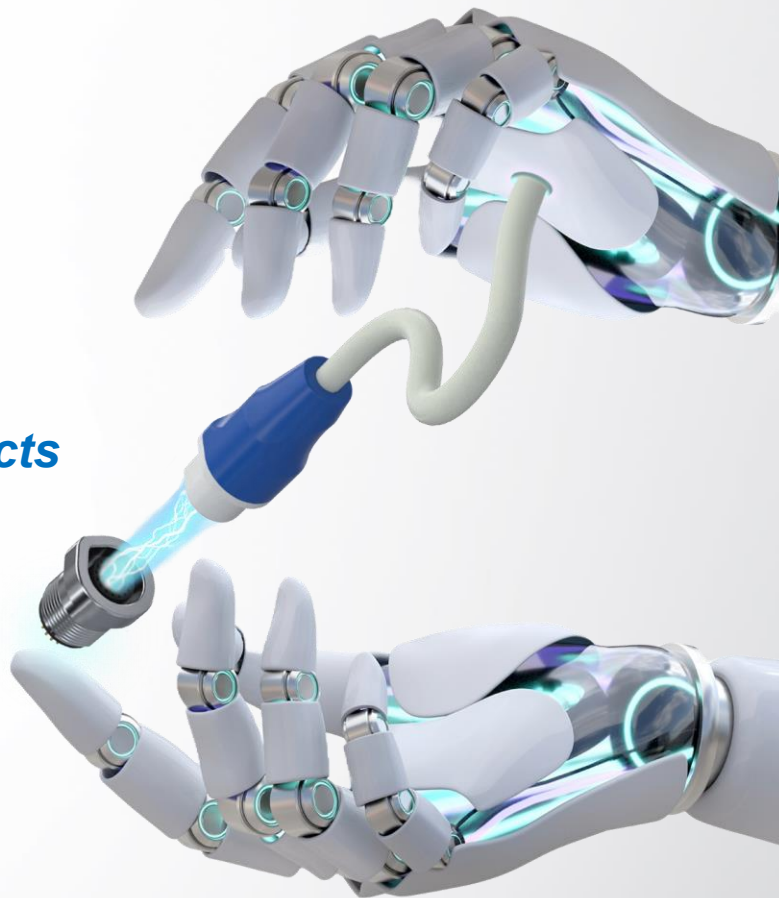



Hill-Rom  
A HILLENBRAND INDUSTRY

<b>Page Description</b>	<b>Page Number</b>
<b>About Onanon</b>	<b>1-2</b>
<b>Quality in Production</b>	<b>3</b>
<b>Automated Manufacturing</b>	<b>4</b>
<b>Overmolding and Encapsulation</b>	<b>5-6</b>
<b>Engineering and Design</b>	<b>7-8</b>
<b>Standard Connectors</b>	<b>A 1-3</b>
<b>RoboSolder®</b>	<b>B 1</b>
<b>MagConnect®</b>	<b>C 1-2</b>
<b>SmartConnect®</b>	<b>C 3-4</b>
<b>BoardConnect®</b>	<b>C 5-6</b>
<b>CableConect®</b>	<b>C 7-8</b>
<b>CustomConect®</b>	<b>C 9-10</b>
<b>Ball &amp; Land Grid Array Socket Systems</b>	<b>D 1-2</b>
<b>Interconnect Pins</b>	<b>E 1-34</b>
<b>Socket Pins</b>	<b>E 2-9</b>
<b>Male Printed Circuit Pins</b>	<b>E 10-26</b>
<b>Bladed Pins</b>	<b>E 27-30</b>
<b>Clip Contacts</b>	<b>E 31-34</b>
<b>Materials</b>	<b>F 1-2</b>



# ABOUT US

## Milpitas, California



Onanon is a leading connector and cable assembly manufacturer headquartered in Milpitas, California, specializing in custom interconnect solutions for medical, automotive, and industrial applications. With a second production facility in Hermosillo, Mexico, we deliver high-quality, scalable manufacturing to meet global demand.

## Hermosillo, Mexico



**Onanon, Inc. is an engineering and manufacturing company capable of producing over 10 million connector components a day, making us one of the largest connector manufacturers in North America.**

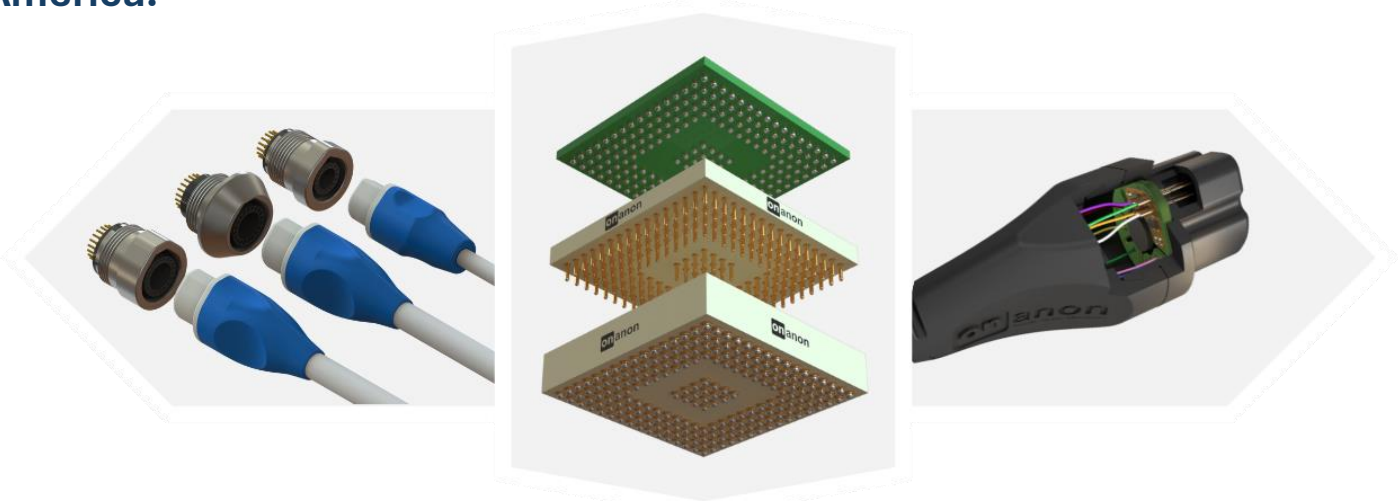

**Established in 1979, Onanon has a tradition of zero defects, on-time delivery and cost competitiveness. Our fully automated Milpitas, California manufacturing facility houses Engineering through Manufacturing.**

**Onanon is particularly distinguished by our proprietary high speed automated machining and assembly processes. This method of manufacturing gives us the flexibility to easily and quickly reconfigure to make any size/shape connector with little to no tooling cost.**

**Our product line features advanced connector solutions like MagConnect® and SmartConnect® designed for medical and industrial applications. We also provide BoardConnect®, focusing on board-to-board, BGA sockets, spring-loaded sockets, pin headers, and a wide range of other application specific interconnect solutions.**

**Onanon products are found in these diverse markets:**

- Medical Cables
- Medical Equipment
- Networking Systems
- Power Supplies
- Scanners
- Test Equipment
- Telecommunications
- AC/DC Converters
- Automotive
- Backplanes
- Broadcasting Equipment
- Computers
- Connectors
- Fiber Optics
- Instrumentation

# Quality in Production



Based on the principles of continuous improvement and the commitment to meet the requirement of ISO 13485, Onanon will meet customer requirements the first time, every time.



Certified

X-Ray Fluorescence Measurement

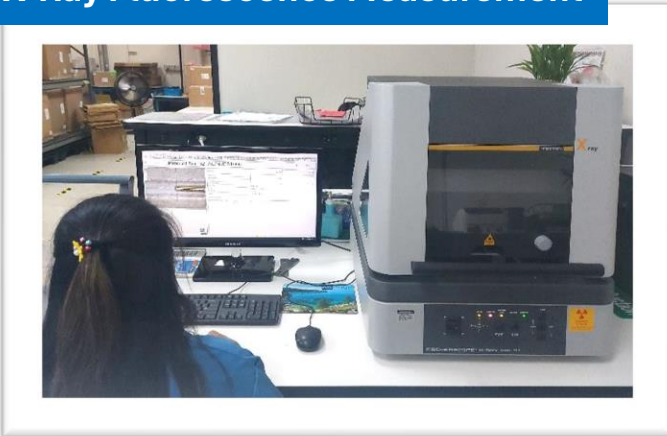

Touch Probe Measurement



Custom Packaging

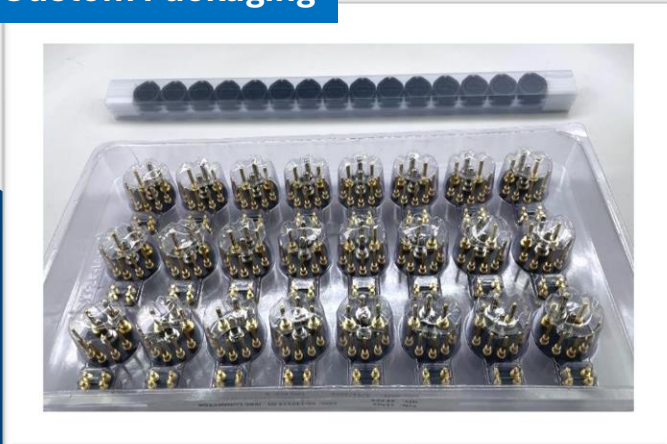

Part Cleanliness Tester

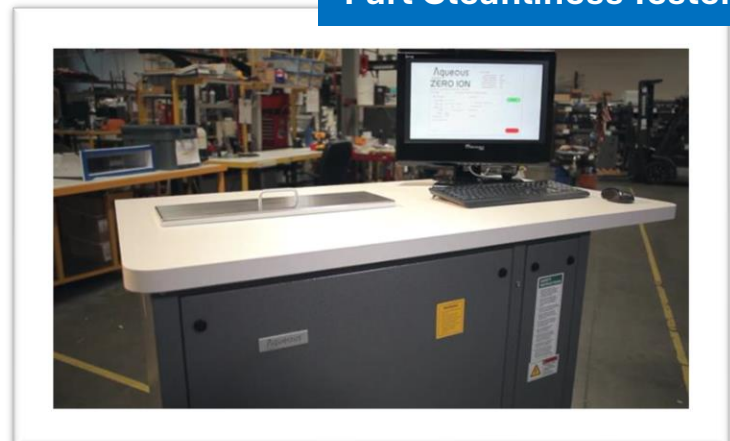

# Automated Manufacturing & Machining

Growth oriented companies have found employing Onanon to source, fabricate and inventory product to be the fastest, most cost-effective way to bring products to the market.



Pin Loading

Onanon is a skilled team of knowledgeable engineers, product managers and trained technicians that continuously seek ways to lower final product cost while raising quality.



Surface Mount Technology (SMT) Assembly

## Expertly Engineered End-to-End Solutions



Overmolding

## Vertically Driven In-House Capabilities



CNC Machining

Using fully automated manufacturing equipment, Onanon has been writing protocols and developing procedures to match the specifications of the most demanding customers worldwide since 1979.

# Overmolding & Electronic Encapsulation

## Variations

### Low Pressure Overmolding

Overmolding is a low pressure/low temperature injection molding process used for encapsulating and protecting delicate electronic components with a thermoplastic material.



### Multistep Overmolding

Two-step Overmolding uses low-pressure molding as the 1<sup>st</sup> encapsulation step to protect the delicate electronics and a 2<sup>nd</sup> shot using regular engineering thermoplastics.



### Epoxy Overmolding

Epoxy Overmolding enhances the resilience of electronic components, making them more resistant to environmental factors and extending their lifespan. Additionally, epoxy materials offer good thermal conductivity, aiding in heat dissipation and overall performance.



## Prototyping

### DFM

Efficiently and cost-effectively produced with minimal complexity and maximum functionality.

### Rapid/Quick Test Tools

3D printing, CNC machining, & other technologies that provide fast and cost-effective ways to create physical prototypes for evaluation and validation.

### Material Selection

We choose the best materials for intended application, performance requirements, and environmental conditions.

### Production Tools

Designed to shape, assemble, or otherwise process materials to create finished products efficiently.

## Contract Manufacturing

Low-to-high volume production

Value added services: engraving / color

Turnkey & supply management.



# Why Choose Us?

## Cost Effective

Overmolding is more cost-effective than traditional potting methods.

## Specifications Reduction

Reduces the weight and space of finished components.

## Ingress Protection & Ruggedization

Encapsulation can make electronics waterproof up to IPX8 and protect them from impacts, strains, and vibrations.

## Sterilization

Ensures safety, regulatory compliance, and the prevention of microbial contamination.

## Resistance to Harsh Chemicals

Withstand exposure to aggressive or corrosive chemical substances without undergoing degradation, damage, or loss of functionality.

## Environmentally Friendly & Safe

Utilizes eco-friendly materials, including recyclable thermoplastics, which align with sustainable manufacturing practices.



## Markets

Medical

Defense

Aerospace

Automotive

Industrial

Commercial



## Onanon's engineering is here to help.

Our goal is to work closely with the customer to efficiently develop products together that are both high quality, cost effective and designed for manufacturing.

Once we understand the application, we can incorporate processes that we have developed in the manufacturing of millions of connectors.

### DESIGN FOR MANUFACTURING

We understand that engineering is a continuous innovation to build a better product. Rapid prototyping is as important as volume production. Nothing beats having a prototype in your hands in days rather than months. It not only helps with “buy in” at the customer, but it also shapes our process for volume production. Our rapid robotic milling allows one or many to flow to you by scheduled delivery for just-in-time production.

### COMPLIANT PIN TECHNOLOGY

Onanon's Compliant Pin Technology enables the integration of PCBAs directly onto connector substrates, allowing for terminal connections and the addition of components like resistors, op-amps, and microprocessors. This creates a flexible, application-specific solution that can serve the needs of multiple devices. By embedding components at the board level, Onanon simplifies design while enhancing performance, offering custom solutions with faster turnaround and lower overall cost.

### RAPID WIRE TERMINATION TECHNOLOGY

Our solder ball rapid wire termination technology not only insures well-fit quick connections, but it also insures connections with low inductance, capacitance and resistance.

### HIGH QUALITY/COST EFFECTIVE

We understand that modern electronics requires high tolerance, strong, light, rugged connectors that are often required to pass wide band signals without distortion. This is what we make.

## From Concept to Connector or Cable Assembly

At Onanon, every solution begins with a deep understanding of your application. Our design process starts by identifying your exact requirements, led by engineers who understand how connectors perform in real-world environments and ends with a solution to your needs.

### After You Submit an RFQ Our engineers take these next steps

#### 1. Product Design

Engineers learn the needs of our customer and design a solution. We communicate with our customer through this whole process.



#### 2. Prototyping

With our in house manufacturing we create a prototype and work with our customers to ensure it meets all their requirements.



#### 3. Tooling

Take proven out designs and create tooling for production level plastics.



#### 4. Qualification

Our engineers conduct rigorous testing and collaborate with you through validation to ensure the final solution once again meets all performance and reliability requirements.



#### 5. Production

After qualification, we transition your project into production with a focus on quality, consistency, and on-time delivery.





## MagConnect® | Rho - Magnetic

- Magnetic latching connector with elliptical keying
- Populates **up to 16 pins**; 3A current; 1kVAC & 1.5kVAC operating voltage; 2 lbf Min
- Designed for modular reusable and disposable systems
- Circuitry with components are easily added via PCBA platform
- Reusable and disposable options with ETO, Gamma, and autoclave safe materials



## MagConnect® | Echo - Magnetic

- Compact magnetic latching connector for high-cycle use
- Populates **up to 20 pins**; 3A current; 1kVAC & 1.5kVDC operating voltage; 3.5 lbf Min
- Designed for surgical, diagnostic, and therapeutic disposable devices
- Circuitry with components are easily added to this connector
- Panel mount or in-line cable configurations; reusable and disposable options with ETO, Gamma, and autoclave safe materials
- Female pins located on panel mount receptacle



## MagConnect® | Hero - Magnetic

- Self-mating magnetic latching connector for critical care systems
- Populates **2-20 pins**; 3A current; 1kVAC and 1.5kVDC operating voltage; 3.5 lbf Min
- Used in reusable high-performance medical environments
- Supports EEPROMs, resistors, and capacitors
- Built with chemical-resistant materials; ETO, Gamma, and autoclave safe
- Female pins located on plug



## MagConnect® | High Voltage - Magnetic

- Magnetic latching connector for high-voltage, rugged environments
- Hybrid **11-pin system**: 5 HV (4.5kV) and 6 LV (2kVDC); 3.3 lbf Min
- Ideal for surgical, diagnostic, aerospace, and industrial tools
- Supports circuit integration with intelligent electronics
- Panel mount or in-line cable formats; reusable and disposable with ETO, Gamma, and autoclave safe materials



## FiberPlus™

- Self-mating, magnetic latching connector used in medical applications
- Hybrid system with up to **8 electrical contacts** and **2 fiber optic connections**
- Option to incorporate circuitry with components into connector
- Designed using chemical-resistant materials; EtO and autoclave safe



## MedLock® | Ultra - High Density

- Ultra high-density connector for large power and bandwidth needs
- Populates **up to 146 pins**; rated to 5 amps & 10Ghrz
- Suitable for a wide range of medical device applications
- Circuitry with components are easily added to this connector
- Reusable and disposable options with ETO, Gamma, and autoclave safe materials





### Medlock® | HD - High Density

- Snap latch connector with elliptical keying for surgical tools
- Populates **up to 62 pins**; rated to 3A; 600 VDC & 500 VAC operating voltage
- Designed for surgical and high-density medical applications
- Circuitry with components are easily added to this connector
- Reusable and disposable options with ETO, Gamma, and autoclave safe materials



### Apollo® - Latching

- Compact snap latch connector with elliptical keying
- Populates **up to 34 pins**; rated to 5 amps & 10Ghrz
- Ideal for surgical and reusable medical devices
- Circuitry with components are easily added to this connector
- Reusable and disposable options with ETO, Gamma, and autoclave safe materials



### Pluto® - Friction Fit

- Small footprint push-pull connector with elliptical keying
- Populates **up to 14 pins**; rated at 5 amps & 10Ghrz
- Suited for compact medical tools and portable devices
- Circuitry with components are easily added to this connector
- Reusable and disposable options with ETO, Gamma, and autoclave safe materials



### Neutrino® - Friction Fit

- Microscale push-pull connector for limited-space applications
- Populates **up to 10 pins**; rated to 3A; 600MΩ @ 800 VDC & 10MΩ @ 400 VAC operating voltage
- Perfect for compact and lightweight medical systems
- Circuitry with components are easily added to this connector
- Reusable and disposable options with ETO, Gamma, and autoclave safe materials



### Redi-Mate™ | 1M Series

- Rugged metal push-pull connector for reusable applications
- Pin count customizable; compatible with circular industry connectors
- Ideal for surgical tools, neuromodulation, and diagnostics
- Secure locking mechanism for reliable connectivity
- Built from sterilizable, durable materials for hospital-grade use



### Redi-Mate™ | 1P Series

- Lightweight plastic push-pull connector for cost-effective applications
- Pin count customizable; built for single-use or semi-disposable designs
- Ideal for imaging, handheld clinical tools, and electrophysiology
- Secure locking mechanism for reliable connectivity
- Compatible with standard connectors and sterilization protocols



**Integrated Electronics**  
**Gamma proof EEPROMs**

**Unlimited Contact**  
**Population Options**

**Any Color**

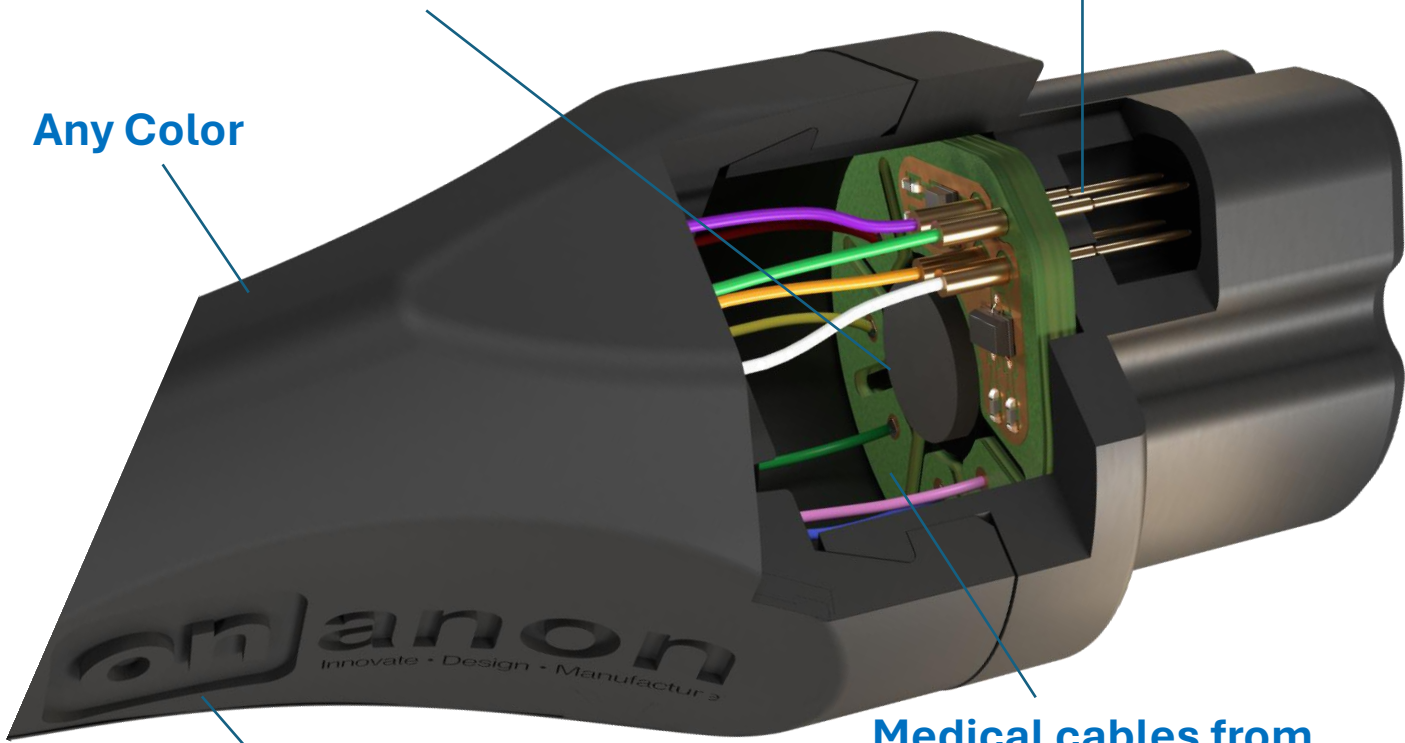

**Your Logo here**

**Medical cables from**  
**20-56awg**

*Our decades of success stories for OEM's allows those who break free from the "wimpy" to prosper with our lower costs solutions. Solutions that are scalable to the OEM's growing electronic device demands. Getting their product to market faster, all with the added benefits of increasing the end users experience. Our turnkey solutions puts OEM's lightyears ahead of their competition.*

*We understand not all OEM's like to lead their industry, and are happy with the expensive "wimpy" but the market leaders, come to Onanon for their muscles!*

**Onanon invented and patented RoboSolder® technology**

**Robotically terminates down to 56awg fine wires to IPC Class III**

**Onanon is the industry leader in terminating wire and cables**



**“Removing the human variable”**

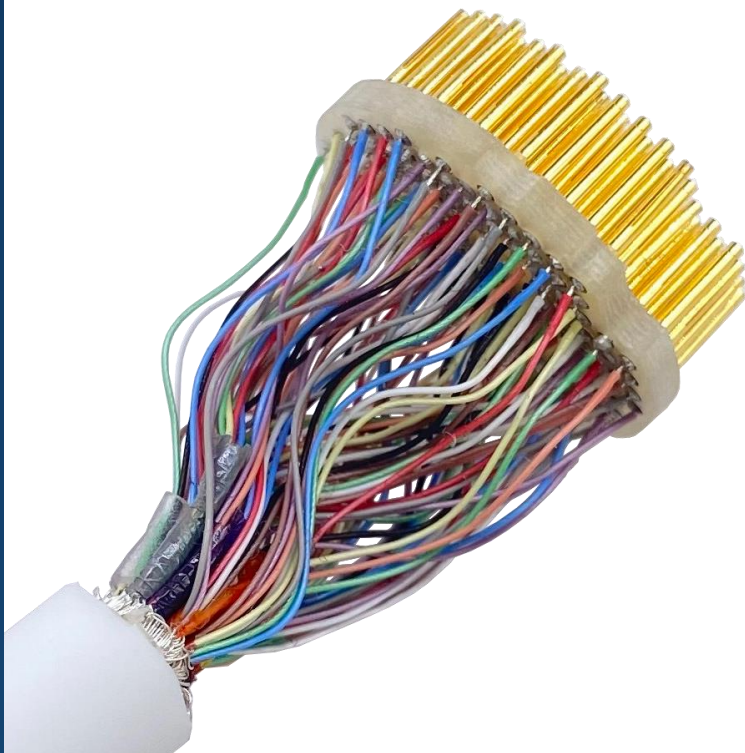

**Solder and Heating Process 100% automated**

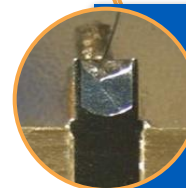

**Accurate and repeatable IPC Class III Standards**



**Programmable to configure around different pinouts**

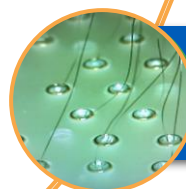

**Terminate 20 to 56 AWG Wires**

## What makes MagConnect® unique?



Onanon's MagConnect® is the most intuitive interconnect in the world with magnetic, self-mating features. It's popular in the medical industry, making the lives of physicians easier and safer to prevent accidents during various medical procedures.

Across medical, industrial, and military spaces, MagConnect® is incredibly easy to use, due to its simple elliptical shape and its ability to magnetically plug itself in. Unlike many basic connectors which can be awkward and cumbersome to plug in, MagConnect® does not require precise key alignment or any force to connect. Simply get the connector close enough and it will plug itself in.

## Industries Served

### Medical Equipment

MagConnect® is popular in the medical industry and is often used with surgical equipment in situations where intuitive quick connection and quick disconnection must occur. The retention force can be modified to ensure patient safety across a variety of procedures.

#### Common Use Cases

- Bronchoscopy
- Ultrasound Devices
- RF Ablation Procedures
- Electrosurgical



# MagConnect®

## Case Studies

“FDA preferred a magnetic safety latch versus a locking connector” – Director of Engineering at Medical Device OEM

### Military Equipment

MagConnect® is popular in the military space, due to its reliability and dependability. It is frequently used in a variety of wearable applications.

#### Common Use Cases

- Wearable Intelligence Equipment
- Communications Equipment
- Missile Launch Applications

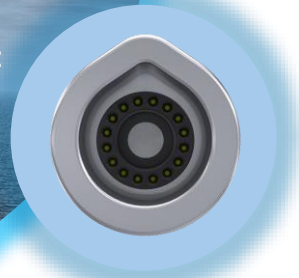

### Industrial Equipment

MagConnect® is often found in a variety of other industrial applications. It is the perfect solution for field technicians when using equipment with hard-to-reach areas.

#### Common Use Cases

- Power Transmission
- Autonomous Mobile Robots
- Automation Equipment
- E-Bikes & E-Scooters

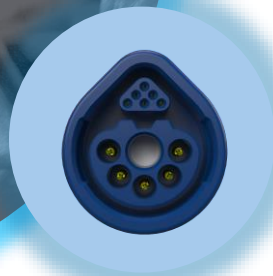

**High Voltage Intravascular Lithotripsy**  
Magconnect® was also the perfect solution for high voltage Intravascular Lithotripsy for Vascular Calcium. The OEM commented that once Magconnect® was seamlessly integrated into their device that it was predictably safe, distinctively intuitive, and consistently effective.

### Laryngoscope

Onanon was approached by a top medical video laryngoscope manufacturer in need of a creative solution for its laryngoscope connectors. Previously, they had been using HDMI connectors for this equipment, HDMI's inability to plug and unplug with ease were causing injuries to patients during procedures..

## What makes SmartConnect® unique?

Onanon's SmartConnect® is an application specific interconnect allowing for digital scalability at the connector and cable level. SmartConnect® utilizes a PCBA within the connector, with electronic components, allowing for one connector to differentiate between multiple different devices.

SmartConnect® allows for a clean and simple solution by having components such as EEPROM's microprocessors, resistors, and capacitors integrated directly into the connector. Customers who cannot easily find a solution for their specific application partner with Onanon as an extension of their own team to design and build a custom SmartConnect® solution from scratch, at a fraction of the time and cost.

### Industries Served

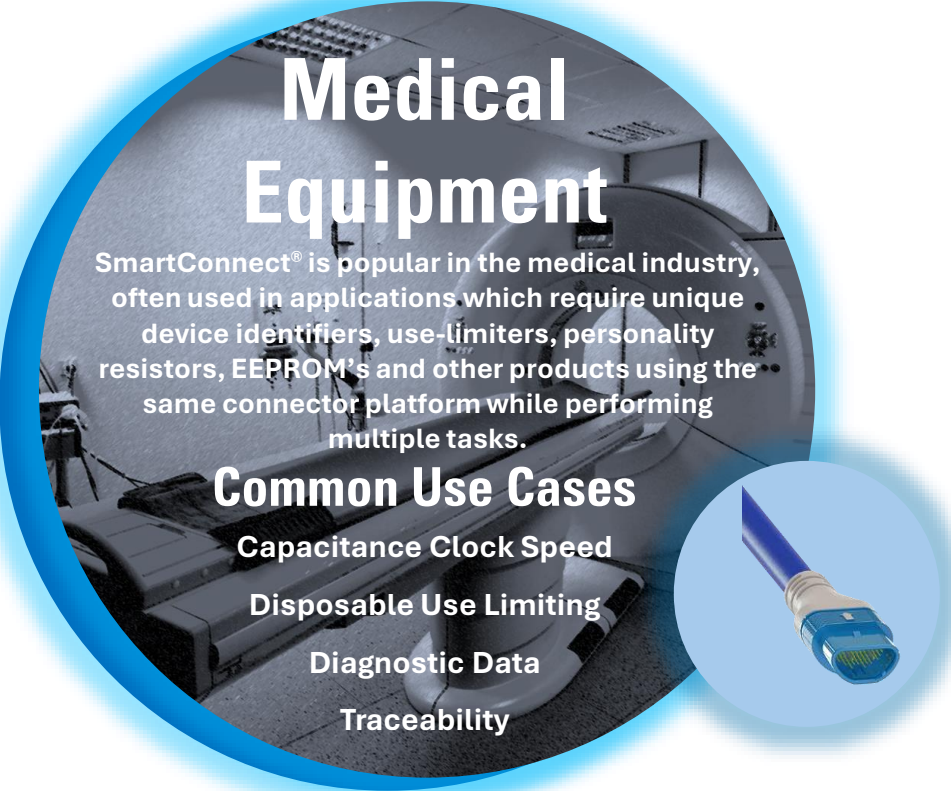

**Medical Equipment**

SmartConnect® is popular in the medical industry, often used in applications which require unique device identifiers, use-limiters, personality resistors, EEPROM's and other products using the same connector platform while performing multiple tasks.

**Common Use Cases**

- Capacitance Clock Speed
- Disposable Use Limiting
- Diagnostic Data
- Traceability



# SmartConnect®

## Case Studies

Onanon was approached by a top medical device OEM that sells over 100 variations of electrosurgical devices.

### Military Equipment

SmartConnect® is used in a variety of military applications, often integrated into wearables to add intelligence within the interconnects.

#### Common Use Cases

- Communication Devices
- Field Failure Diagnostics
- Wearables



### Agricultural Equipment

SmartConnect® can be found in the agricultural industry in an assortment of smart electromechanical agricultural equipment.

#### Common Use Cases

- IP Rated Cables for Tractor
- Sprayers
- Headers with Built-in Capacitance
- Wire Harnesses



After speaking with them and learning about their product requirements, we set out to design a SmartConnect® that would work with all of these product variations with one connector with built in electronics.

We created a universal SmartConnect® that had integrated device recognition. As soon as the device is plugged in, the equipment recognizes the device and immediately turns on all the correct settings. In addition to improving ease of use and convenience, this also eliminated any human error associated with altering settings on a device before a procedure.

## What makes BoardConnect® unique?

Scan here to Build-a-Socket!



Onanon's BoardConnect® represents Onanon's robust capabilities when it comes to designing customizable board to board connectors for a variety of applications.

BoardConnect® is not a one-size-fits-all solution, but a custom solution tailor-made for your application. It can be assembled as a board-to-board connector or as a cable assembly with a connector on it to connect it to a circuit board.

## Industries Served

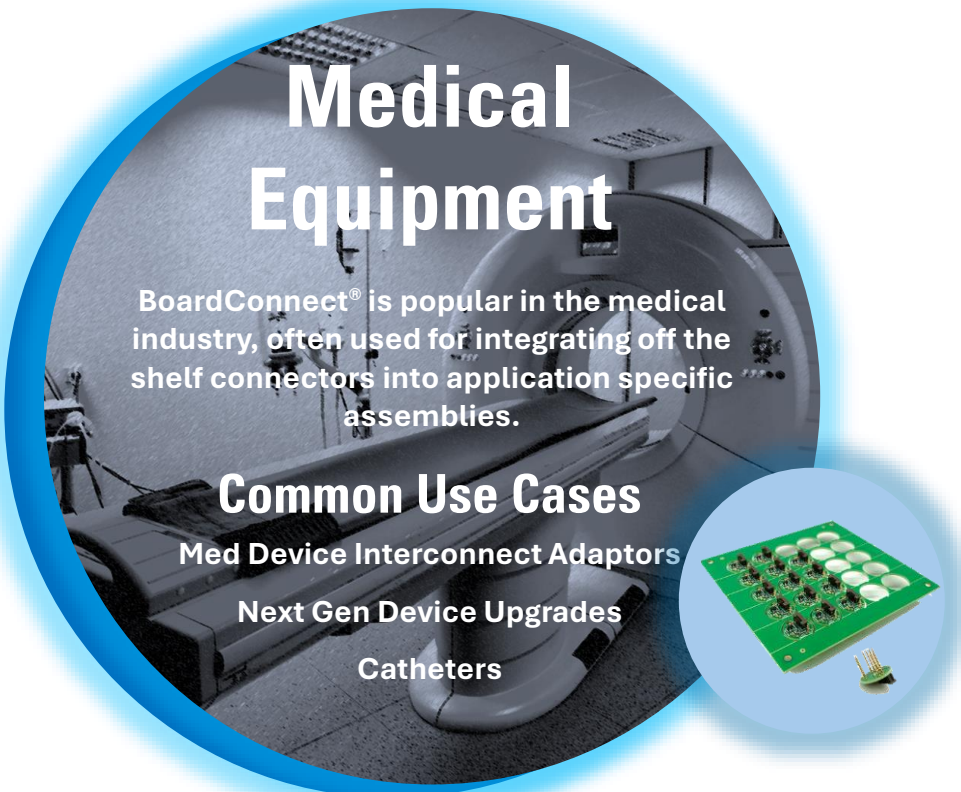

**Medical Equipment**

BoardConnect® is popular in the medical industry, often used for integrating off the shelf connectors into application specific assemblies.

**Common Use Cases**

- Med Device Interconnect Adaptors
- Next Gen Device Upgrades
- Catheters

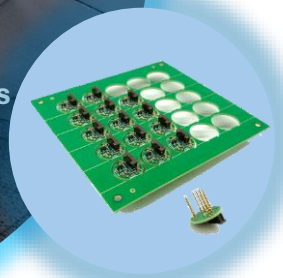

# BoardConnect® Case Studies

BoardConnect® can be designed for a variety of applications.

## Military Equipment

BoardConnect® is often found in many applications in the military space, due to its reliability and dependability. It is frequently used in a variety of applications.

### Common Use Cases

Board Connect with Flex  
High Density

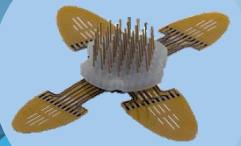

## Agricultural Equipment

BoardConnect® is frequently found in the agricultural space, used in smart tractors and other intelligent harvesting equipment.

### Common Use Cases

Right Angle PCB Connectors  
Bladed Headers

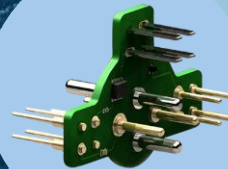

One customer, a top military interconnect manufacturer, came to us in a dire situation which was costing their end customer over \$10,000 a day. They needed a custom board to board connector and provided us with a rough concept of what they needed.

Our engineering team was able to provide a drawing complete with tolerancing, DFM suggestions, and a cost competitive quote that same day. We manufactured their custom board solution and had it shipped within 4 days, a quick turnaround time when compared to the industry average of 4-6 weeks. In the process, we ended up saving them nearly \$100,000.

## What makes CableConnect® unique?

Onanon's CableConnect® is another example of Onanon's creativity, ingenuity, and flexibility when it comes to designing custom cable assembly solutions for our customers. Decades of experience in the medical, industrial, military markets with fine wire (30-50 awg), high conductor count, micro-coax, high impedance, high voltage and silicone requirements together with a deep understanding of cable design engineering, have given us the ability to design cable assemblies that optimize function, performance, value, and appearance.

### Industries Served

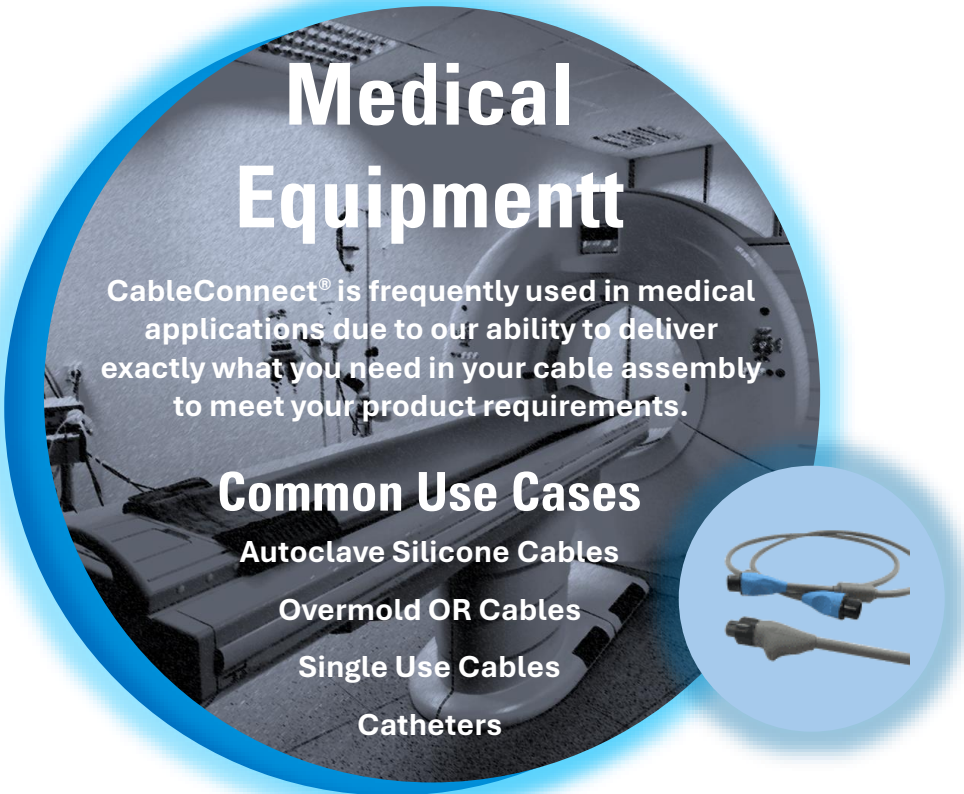

**Medical Equipment**

CableConnect® is frequently used in medical applications due to our ability to deliver exactly what you need in your cable assembly to meet your product requirements.

**Common Use Cases**

- Autoclave Silicone Cables
- Overmold OR Cables
- Single Use Cables
- Catheters



# CableConnect®

## Case Studies

A top medical robotics company needed a cable assembly that would fit into a very tight space within the cartridge of a disposable robotic arm.

### Military Equipment

CableConnect® is a trusted tool of the military, and is frequently found in a variety of applications, such as custom self-mating and decoupling cables on wearable equipment.

#### Common Use Cases

- Self-Mating Cables on Wearables
- Self-Cleaning Interconnects



### Agricultural Equipment

Onanon's CableConnect® has revolutionized the agriculture industry helping steward the industries evolution from mechanical to electromechanical and electrification, in the harsh environment that is the agricultural industry.

#### Common Use Cases

- Intelligent Harvesters/Combines
- Hi-tech Sprayer Systems
- Wire Harnesses
- Turf Equipment



Additionally, it needed to be hermetically sealed so that no gas, air, or other substances would leak in and compromise the integrity of the assembly. The sensor inside needed to be able to work under harsh conditions, including high temperatures, humidity, vibration, and exposure to chemicals.

This assembly would be used in robotic surgery equipment, so it was critical that it would be able to withstand these conditions. This medical robotics company was unable to find this specific solution anywhere else, so they approached Onanon to help design it from scratch.

## What makes CustomConnect® unique?

Onanon's CustomConnect® represents Onanon's broad and flexible capabilities when it comes to producing custom interconnect solutions. CustomConnect® is not a one-size-fits-all solution, but a customizable interconnect made specifically for your application. Onanon's representatives will talk to you, figure out exactly what you need, take your specifications and product requirements, and bring them to life. Our vast expertise in electromechanical interconnect allows us to design interconnects that optimize function, value, and appearance.

### Industries Served

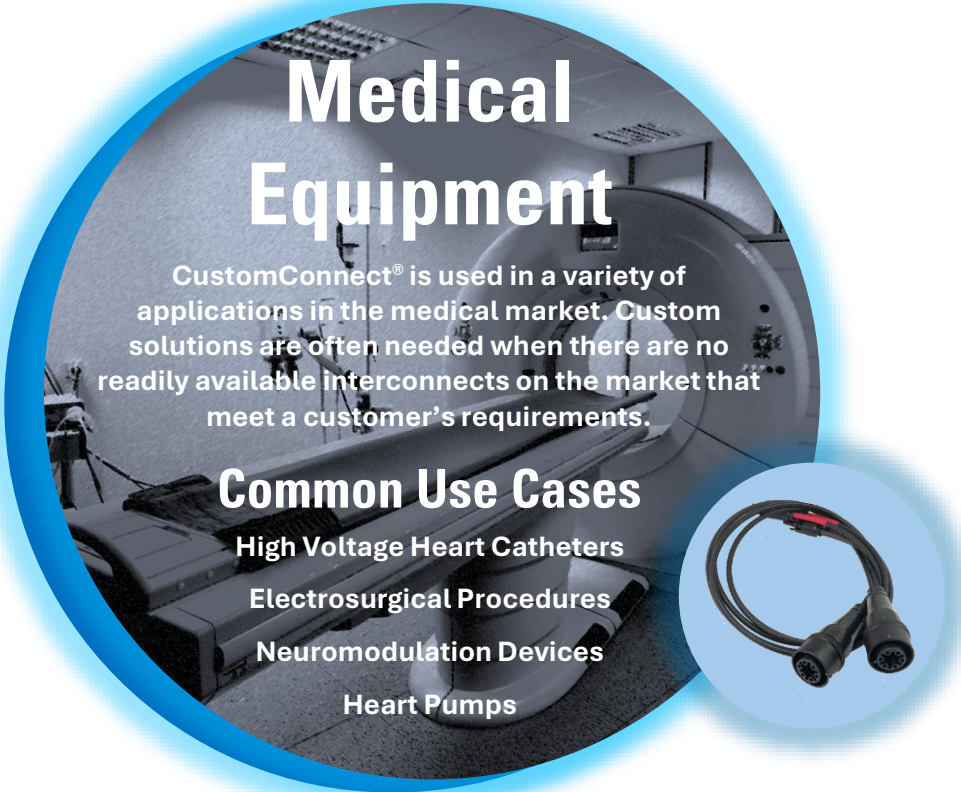

**Medical Equipment**

CustomConnect® is used in a variety of applications in the medical market. Custom solutions are often needed when there are no readily available interconnects on the market that meet a customer's requirements.

**Common Use Cases**

- High Voltage Heart Catheters
- Electrosurgical Procedures
- Neuromodulation Devices
- Heart Pumps



# CustomConnect®

## Case Studies



### The Problem

The existing design relied on non-value added manual gluing, crimping, taping, and overall poor design for manufacturability, adding cost, quality issues and reliability issues in the field. Surgeons were also experiencing fatigue during this time-consuming operation which requires precision and dexterity from the surgeon. The instruments were causing unneeded strain, discomfort and fatigue in the surgeon's hands. Surgeons had to use foot pedals in conjunction with the instruments to complete procedures. This led the OEM to approach Onanon for help to make their product and reliable at a disposable cost point.

### Our Solution

Onanon designed a CustomConnect® solution which removed all manual gluing, taping and crimping operations to name a few. The new design allowed it to be a plug and play device eliminating all scrap throughout the supply chain. Onanon redesigned the device to be more user friendly, improving the tactile feel, grip and button performance so that surgeons could more easily perform the operation without any of the strain, discomfort, or fatigue experienced previously. This also eliminated the need to use the additional foot pedal during procedures. All in all, Onanon's CustomConnect® solution led to a better product, which meant that surgeons were able to perform operations with more safety, efficiency and reliability.

### Industrial Equipment

Onanon can integrate proven electromechanical methodologies to create the perfect custom solution for industrial applications to match the rapidly changing needs of the fast-paced industry moving from mechanical to electromechanical.

### Common Use Cases

- Aerospace
- Agriculture
- Robotics
- Lidar

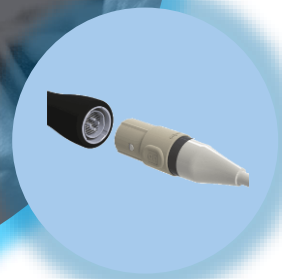

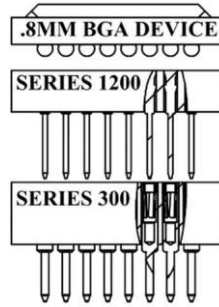
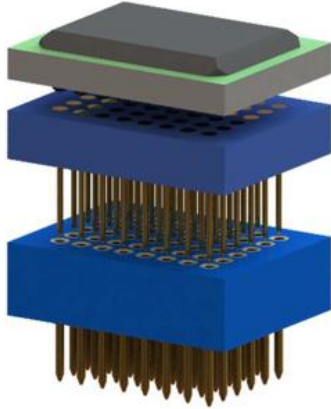

**THRU HOLE**

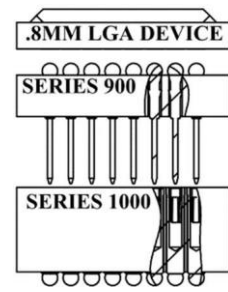

**SURFACE MOUNT**

**PERFORMANCE AND MATERIALS SPECIFICATIONS**

**Thermal Performance [FR-4 Standard]:**

Operating Temperature Range:	-55° to 140°C
Glass Transition Temperature Range:	150° to 200°C
Resistance to Soldering Heat:	10 seconds @ 288°C
Flammability Rating [UL-94]:	UL94V-0
IEC Climatic Category:	55/125/21

**Electrical Performance: Tests IAW MIL-STD-202 or 1344 Methods:**

Maximum Voltage:	75 VAC / 100 VDC
Maximum Current:	1 Amperes per contact
Contact Resistance: Dry Circuit:	.01 Ω Max. @ .1 Amps/5 VDC
Insulation Resistance, @ 500 VDC	10,000 MegOhms Min.
Dielectric Withstanding Voltage	500 VAC Min.
Capacitance:	1 pf [PicoFarads] Max.
Self Inductance	2 nH [NanoHenries] Max.

**Contact Materials & Finishes [Other finishes available]:**

Bodies:	Brass Alloy C36000 per ASTM-B16, ½ Hard
Plated	10µln. Min. Gold over 100µln. Min. Nickel, [or] 100µln. Min. Tin Over 100µln. Min. Nickel
Contacts:	Beryllium Copper Alloy C17200 per ASTM-B194 Plated
	10µln. Min. Gold over 50µln. Min. Nickel
Solder Balls:	Eutectic, Sn 96.5/Ag 3.0/Cu .5 Solder, Ø.015 ~ Ø.020
	Melting Temperature 218.5° C [425.3°F]

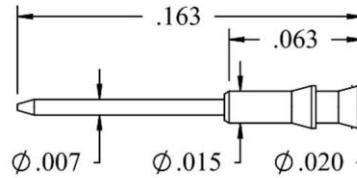

**P/N 0108**

Ø.020 EUTECTIC SOLDER BALL [SERIES 900] LEAD FREE

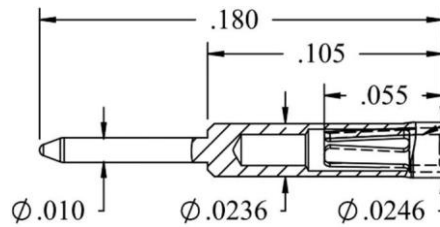

**P/N 0114**

CONTACT P/N 0130

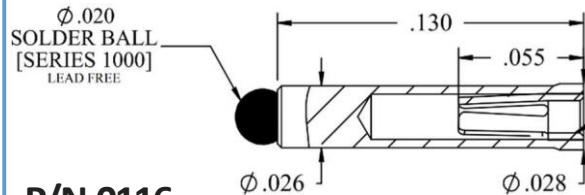

**P/N 0116**

CONTACT P/N 0130

**PART NUMBER: ORDERING INFORMATION**

**300**

**100**

**F - 0104**

**10A3**

**PRODUCT CODE**

**PIN COUNT**

**MATERIAL CONTACT P/N**

**PATTERN CODE**

- 300 = Socket Pin Grid Array [PGA]
- 900 = LGA Interposer [BPGA]
- 1000 = Socket, Ball Grid Array [SBGA]
- 1200 = Ball Grid Array Interposer [PBGA]

- A = ACRYLIC
- E = PEEK [POLYETHERETHERKETONE]
- H = POLYIMIDE, [MIL-L-13949/10]
- F = FR-4, [IPC 4101/24]
- R = RYTON [POLYPHENYLENE SULFIDE]
- U = G.E. ULTEM [POLYETHERIMIDE]

- OVER 25,000 PATTERNS AVAILABLE

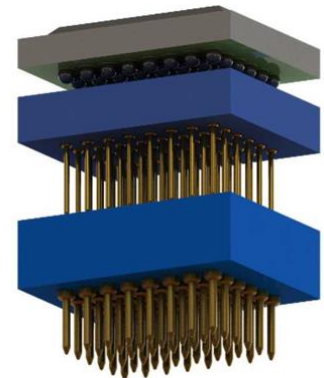

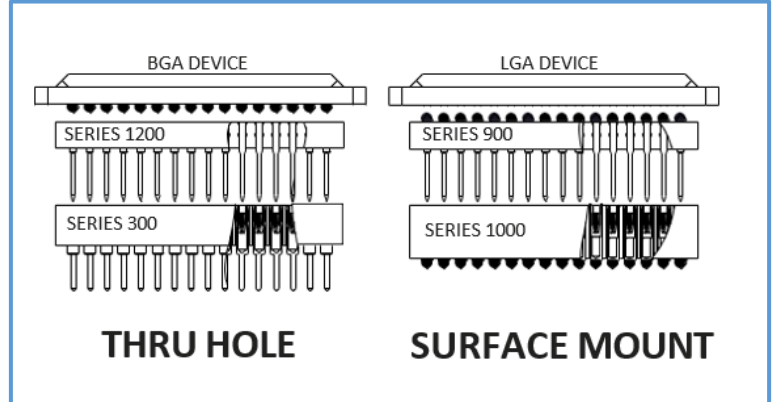
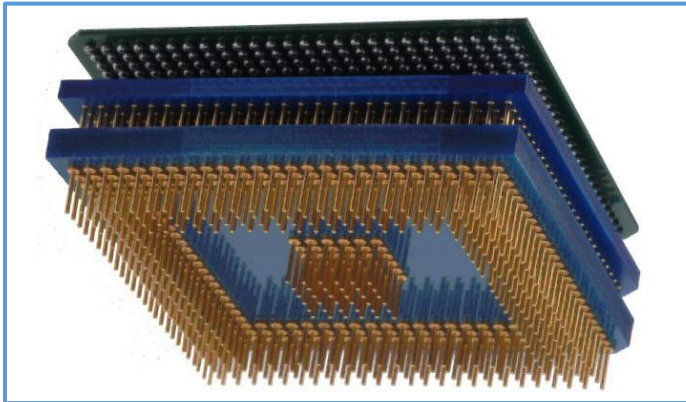

## PERFORMANCE AND MATERIALS SPECIFICATIONS

### Thermal Performance [FR-4 Standard]:

Operating Temperature Range:	-55° to 140°C
Glass Transition Temperature Range:	150° to 200°C
Resistance to Soldering Heat:	10 seconds @ 288°C
Flammability Rating [UL-94]:	UL94V-0
IEC Climatic Category:	55/125/21

### Electrical Performance: Tests IAW MIL-STD-202 or 1344 Methods:

Maximum Voltage:	75 VAC / 100 VDC
Maximum Current:	1 Amperes per contact Contact
Resistance: Dry Circuit:	.01 Ω Max. @ .1 Amps/5 VDC
Insulation Resistance, @ 500 VDC	10,000 MΩ Min.
Dielectric Withstanding Voltage	500 VAC Min.
Capacitance:	1 pf [PicoFarads] Max.
Self Inductance	2 nH [NanoHenries] Max.

### Contact Materials & Finishes [Other finishes available]:

Bodies:	Brass Alloy C36000 per ASTM-B16, ½ Hard Plated 10µln. Min. Gold over 100µln. Min. Nickel, [or] 100µln. Min. Tin Over 100µln. Min. Nickel
Contacts:	Beryllium Copper Alloy C17200 per ASTM-B194 Plated 10µln. Min. Gold over 50µln. Min. Nickel
Solder Balls:	Eutectic, Sn 96.5/Ag 3.0/Cu .5 Solder, Ø.015 ~ Ø.020 Melting Temperature 218.5° C [425.3°F]

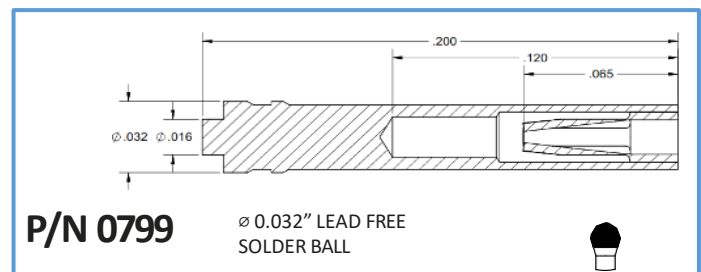
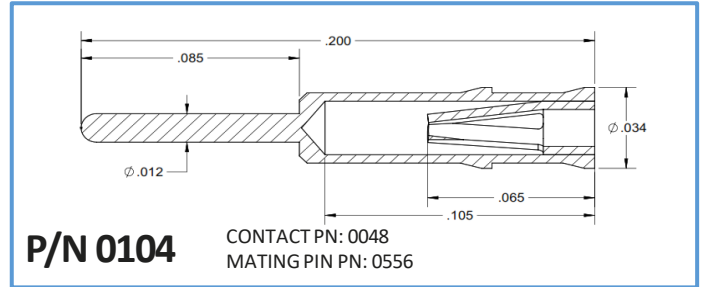
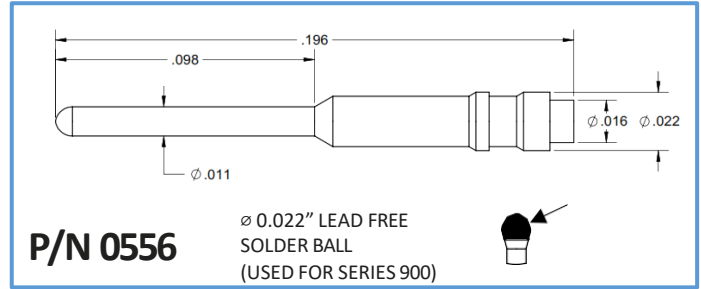

## PART NUMBER: ORDERING INFORMATION



**300**  
PRODUCT CODE



**640** - **F**  
PIN COUNT      MATERIAL

**0556** - **11A4**  
CONTACT P/N      PATTERN CODE

OVER 25,000 PATTERNS AVAILABLE

- 300 = Socket Pin Grid Array [PGA]
- 900 = LGA Interposer [BPGA]
- 1000 = Socket, Ball Grid Array [SBGA]
- 1200 = Ball Grid Array Interposer [PBGA]

- A = ACRYLIC
- E = PEEK [POLYETHERETHERKETONE]
- H = POLYIMIDE, [MIL-L-13949/10]
- F = FR-4, [IPC 4101/24]
- R = RYTON [POLYPHENYLENE SULFIDE]
- U = G.E. ULTEM [POLYETHERIMIDE]

If unknown put XXXX  
Factory will add pattern code

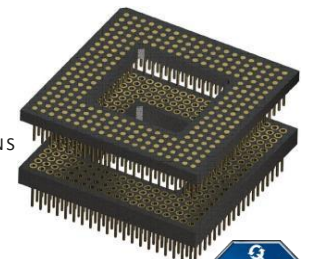

## SOCKET PINS



Socket pins are single components that have inner BeCu clip that feature multi-finger contact and are fastened to PCB by being press-fit or solder mount. It is primarily used for plugging and unplugging of components on PCB and can accommodate round, square, or rectangular leads.

## PRINTED CIRCUIT PINS



Printed Circuit Pins are fastened to PCB by being press-fit or solder mount. These pins are used for numerous plug-in applications and PCB to PCB interconnection.

## CONTACTS & CLIPS



Contacts, also called clips, are round multi-finger components with spring properties which are primarily used for plugging and unplugging of components on PCB. Clips are able to accept a broad range of mating pin diameters from 0.007" to 0.102" and maintain retentions after multiple insertions.

Socket Pins, Printed Circuit Pins, and Contacts are electronic interconnect devices for printed circuit boards. These pins are made of metallic elements or alloys. Socket Pins and Printed Circuit Pins are mainly machined of Brass Alloy C36000 per ASTM-B16 and has a finish of either Gold over Nickel or Tin over Nickel. Contacts are made of BeCu (Beryllium Copper) Alloy C17200 per ASTM-B194 and has a finish of either Gold over Nickel or Tin over Nickel.

### 0114

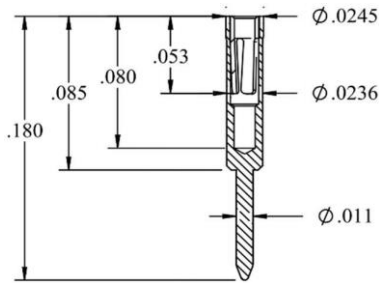

PLATING: Au/Ni CONTACT P/N: 0130  
SHELL: BeCu MATING PIN:  
CONTACT: Au/Ni Ø.006 - Ø.011 [Ø.15 - Ø.28]

### 0116

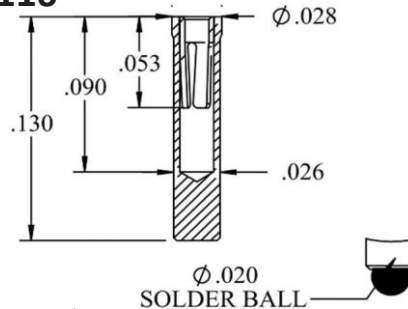

PLATING: Au/Ni CONTACT P/N: 0130  
SHELL: BeCu MATING PIN:  
CONTACT: Au/Ni Ø.006 - Ø.011 [Ø.15 - Ø.28]

### 0169

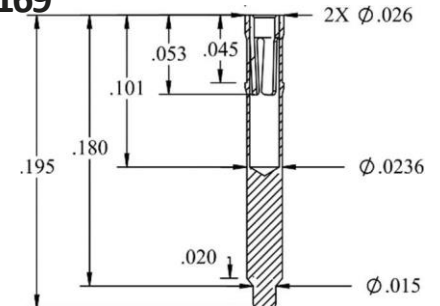

PLATING: Au/Ni CONTACT P/N: 0130  
SHELL: BeCu MATING PIN:  
CONTACT: Au/Ni Ø.006 - Ø.011 [Ø.15 - Ø.28]

### 0205

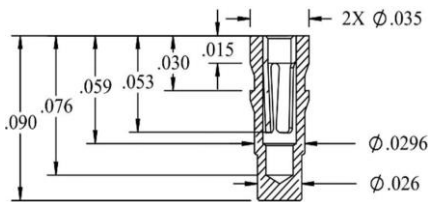

PLATING: Au/Ni CONTACT P/N: 0130  
SHELL: BeCu MATING PIN:  
CONTACT: Au/Ni Ø.006 - Ø.011 [Ø.15 - Ø.28]

### 0339

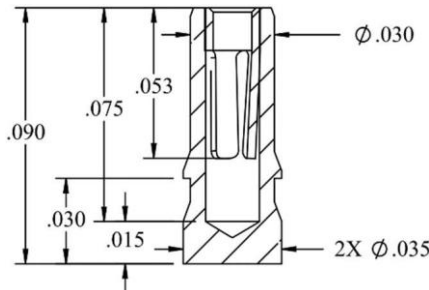

PLATING: Au/Ni CONTACT P/N: 0311  
SHELL: BeCu MATING PIN:  
CONTACT: Au/Ni Ø.006 - Ø.011 [Ø.15 - Ø.28]

### 0355

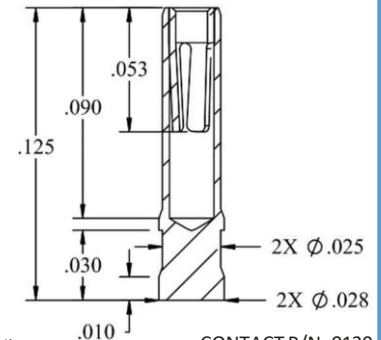

PLATING: Au/Ni CONTACT P/N: 0130  
SHELL: BeCu MATING PIN:  
CONTACT: Au/Ni Ø.006 - Ø.011 [Ø.15 - Ø.28]

PART NO	FINISH
0130	Au/Ni
0311	Sn/Ni

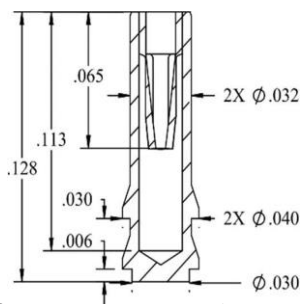

PLATING: See Table CONTACT P/N: 0048  
SHELL: See Table MATING PIN:  
CONTACT: Au/Ni Ø.007 - Ø.013 [Ø.15 - Ø.28]

### 0417

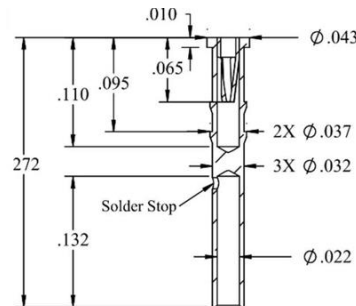

PLATING: Au/Ni CONTACT P/N: 0048  
SHELL: BeCu MATING PIN:  
CONTACT: Au/Ni Ø.007 - Ø.013 [Ø.15 - Ø.28]

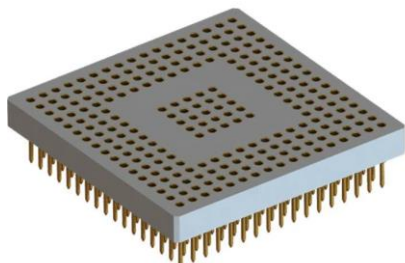

#### NOTES: UNLESS OTHERWISE SPECIFIED

##### SHELL / BODIES

##### MATERIAL \ FINISH

BRASS ALLOY C36000 per ASTM-B16, Half Hard plated Gold per MIL-G-45204 Type 2, Grade C, 10µ In. Min. over Nickel, 100µ In. Min. per QQ-N-290 Class 4. Or Tin per MIL-T-10727 Type I, 200µ In. Min. over Nickel 100µ In. Min.

##### CONTACTS

##### MATERIAL \ FINISH

Beryllium Copper, Alloy C17200 per ASTM-B194, heat treated, plated Gold per MIL-G-45204 Type 2, Grade C, Class 0, 30µ In. Min. or Class 00, 10µ In. Min., over Nickel per QQ-N-290 Class 4, 50µ In. Min. Or; Tin per MIL-T-10727 Type I, 200µ In. Min over Nickel, 50µ In. Min.

DIMENSIONS ARE IN INCHES

DIMENSIONAL TOLERANCES:

DRAWINGS NOT TO SCALE

DIAMETERS  
±.002

ANGLES  
±2°

LENGTHS  
±.005

**0004**

PLATING: Au/Ni CONTACT P/N: 0048  
SHELL: BeCu MATING PIN:  
CONTACT: Au/Ni Ø.007 - Ø.012 [Ø.18 - Ø.31]

**0012**

PLATING: Au/Ni CONTACT P/N: 0069  
SHELL: BeCu MATING PIN:  
CONTACT: Au/Ni Ø.015 - Ø.020 [Ø.38 - Ø.51]

PART NO	"A"
0024	.440
0311	.180
0183	.125

PLATING: Au/Ni CONTACT P/N: 0132  
SHELL: BeCu MATING PIN:  
CONTACT: Au/Ni Ø.015 - Ø.020 [Ø.38 - Ø.51]

**0027**

PLATING: Au/Ni CONTACT P/N: 0048  
SHELL: BeCu MATING PIN:  
CONTACT: Au/Ni Ø.007 - Ø.012 [Ø.18 - Ø.31]

**0030**

PLATING: Au/Ni CONTACT P/N: 0069  
SHELL: BeCu MATING PIN:  
CONTACT: Au/Ni Ø.015 - Ø.020 [Ø.38 - Ø.51]

**0045**

PLATING: Au/Ni CONTACT P/N: 0132  
SHELL: BeCu MATING PIN:  
CONTACT: Au/Ni Ø.015 - Ø.020 [Ø.38 - Ø.51]

PART NO	"A"
0049	.500
0094	.650

PLATING: Au/Ni CONTACT P/N: 0069  
SHELL: BeCu MATING PIN:  
CONTACT: Au/Ni Ø.015 - Ø.020 [Ø.38 - Ø.51]

**0050**

PLATING: Au/Ni CONTACT P/N: 0048  
SHELL: BeCu MATING PIN:  
CONTACT: Au/Ni Ø.007 - Ø.012 [Ø.18 - Ø.31]

PART NO	"A"
0051 [0080]	.365
0083	.515

PLATING: Au/Ni CONTACT P/N: 0048  
SHELL: BeCu MATING PIN:  
PIN: CONTACT: Au/Ni Ø.007 - Ø.012 [Ø.18 - Ø.31]

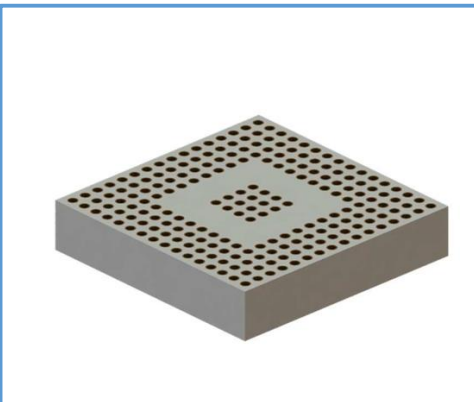

**NOTES: UNLESS OTHERWISE SPECIFIED**

SHELL / BODIES

MATERIAL \ FINISH

BRASS ALLOY C36000 per ASTM-B16, Half Hard plated Gold per MIL-G-45204 Type 2, Grade C, 10µ In. Min. over Nickel, 100µ In. Min. per QQ-N-290 Class 4. Or Tin per MIL-T-10727 Type I, 200µ In. Min. over Nickel 100µ In. Min.

CONTACTS

MATERIAL \ FINISH

Beryllium Copper, Alloy C17200 per ASTM-B194, heat treated, plated Gold per MIL-G-45204 Type 2, Grade C, Class 0, 30µIn. Min. or Class 00, 10µIn. Min., over Nickel per QQ-N-290 Class 4, 50µIn. Min. Or; Tin per MIL-T-10727 Type I, 200µIn. Min over Nickel, 50µIn. Min.

DIMENSIONS ARE IN INCHES

DIMENSIONAL TOLERANCES:

DRAWINGS NOT TO SCALE

DIAMETERS  
±.002

ANGLES  
±2°

LENGTHS  
±.005

**0055**

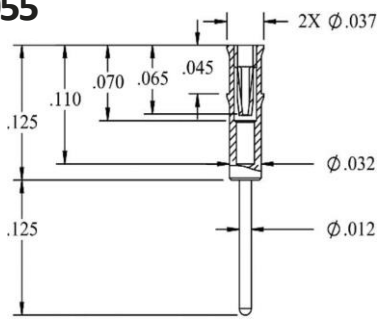

PLATING: Au/Ni CONTACT P/N: 0048  
SHELL: BeCu MATING PIN:  
CONTACT: Au/Ni Ø.007 - Ø.012 [Ø.18 - Ø.31]

**0056**

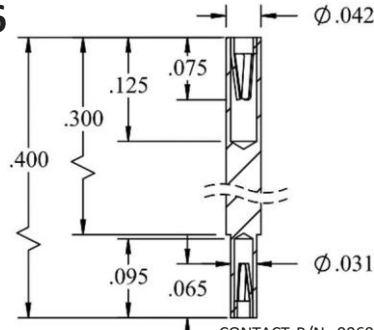

PLATING: Au/Ni CONTACT P/N: 0069 (TOP)  
SHELL: BeCu MATING PIN: Ø.006 - Ø.011 [Ø.15 - Ø.28]  
CONTACT: Au/Ni CONTACT P/N: 0048 (BOTTOM)  
MATING PIN: Ø.007 - Ø.012 [Ø.18 - Ø.33]

**0060**

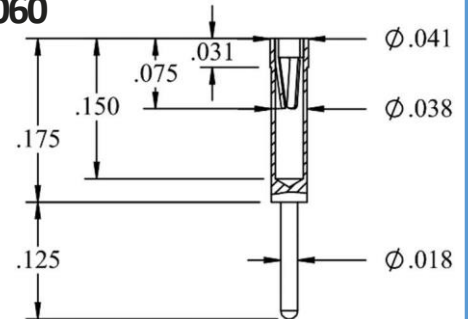

PLATING: Au/Ni CONTACT P/N: 0069  
SHELL: BeCu MATING PIN:  
CONTACT: Au/Ni Ø.015 - Ø.020 [Ø.38 - Ø.51]

**0065**

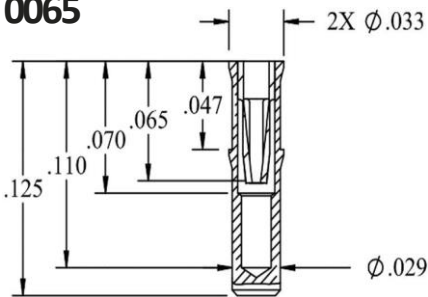

PLATING: Au/Ni CONTACT P/N: 0048  
SHELL: BeCu MATING PIN:  
CONTACT: Au/Ni Ø.007 - Ø.012 [Ø.18 - Ø.31]

PART NO	FINISH
0074	Sn/Ni
0075	Au/Ni

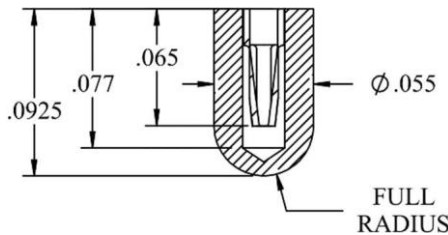

PLATING: Au/Ni CONTACT P/N: 0048  
SHELL: See Table MATING PIN:  
CONTACT: Au/Ni Ø.007 - Ø.012 [Ø.18 - Ø.31]

PART NO	"A"
0082	.515
0093	.365

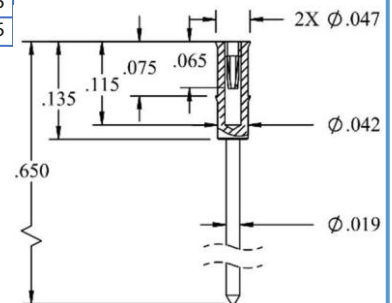

PLATING: Au/Ni CONTACT P/N: 0069  
SHELL: BeCu MATING PIN:  
CONTACT: Au/Ni Ø.015 - Ø.020 [Ø.38 - Ø.51]

**0100**

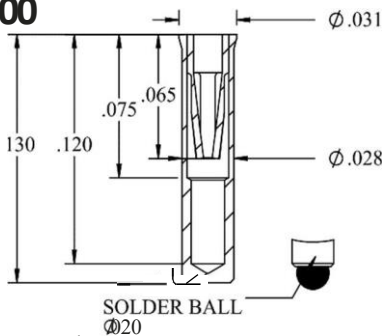

PLATING: Au/Ni CONTACT P/N: 0048  
SHELL: BeCu MATING PIN:  
CONTACT: Au/Ni Ø.007 - Ø.012 [Ø.18 - Ø.31]

**0103**

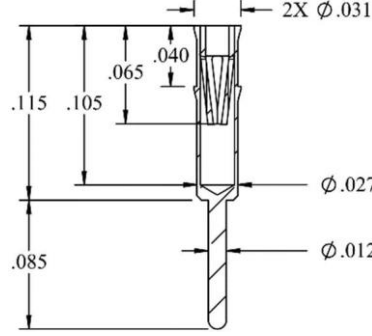

PLATING: Au/Ni CONTACT P/N: 0048  
SHELL: BeCu MATING PIN:  
CONTACT: Au/Ni Ø.007 - Ø.012 [Ø.18 - Ø.31]

**0104**

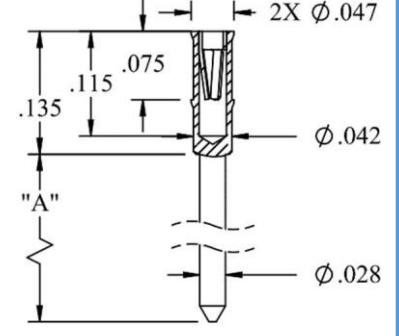

PLATING: Au/Ni CONTACT P/N: 0048  
SHELL: BeCu MATING PIN:  
CONTACT: Au/Ni Ø.007 - Ø.012 [Ø.18 - Ø.31]

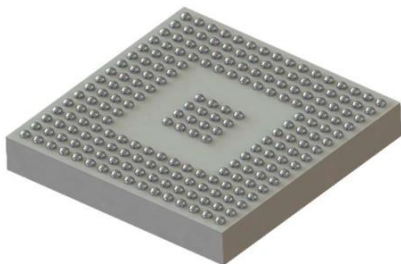

**NOTES: UNLESS OTHERWISE SPECIFIED**

SHELL / BODIES

MATERIAL \ FINISH

BRASS ALLOY C36000 per ASTM-B16, Half Hard plated Gold per MIL-G-45204 Type 2, Grade C, 10µ In. Min. over Nickel, 100µ In. Min. per QQ-N-290 Class 4. Or Tin per MIL-T-10727 Type I, 200µ In. Min. over Nickel 100µ In. Min.

DIMENSIONS ARE IN INCHES

DIMENSIONAL TOLERANCES:

DRAWINGS NOT TO SCALE

DIAMETERS  
±.002

ANGLES  
±2°

LENGTHS  
±.005

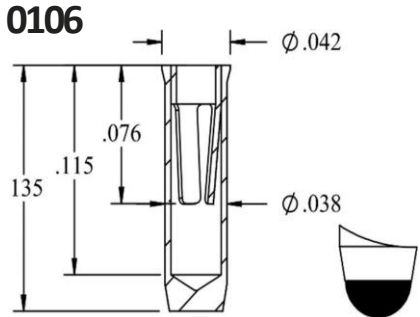

PLATING: Au/Ni CONTACT P/N: 0132  
SHELL: BeCu MATING PIN:  
CONTACT: Au/Ni Ø.015 - Ø.020 [Ø.38 - Ø.51]

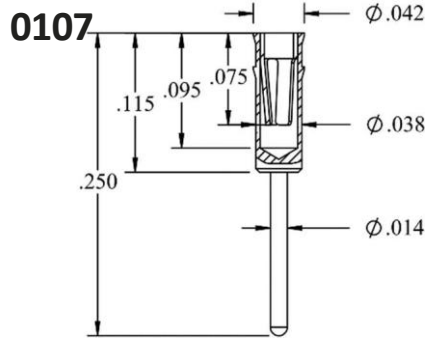

PLATING: Au/Ni CONTACT P/N: 0132  
SHELL: BeCu MATING PIN:  
CONTACT: Au/Ni Ø.015 - Ø.020 [Ø.38 - Ø.51]

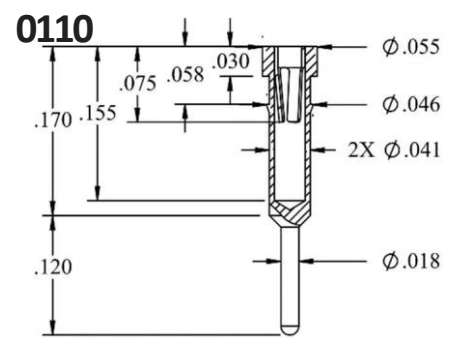

PLATING: Au/Ni CONTACT P/N: 0132  
SHELL: BeCu MATING PIN:  
CONTACT: Au/Ni Ø.015 - Ø.020 [Ø.38 - Ø.51]

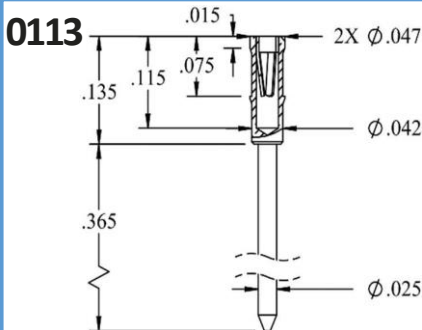

PLATING: Au/Ni CONTACT P/N: 0069  
SHELL: BeCu MATING PIN:  
CONTACT: Au/Ni Ø.015 - Ø.020 [Ø.38 - Ø.51]

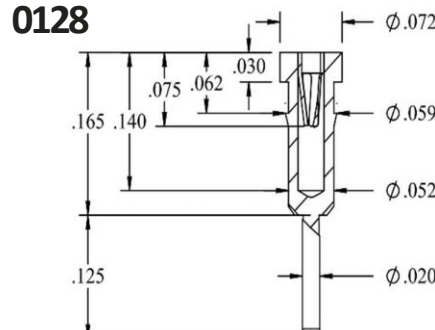

PLATING: Au/Ni CONTACT P/N: 0286  
SHELL: BeCu MATING PIN:  
CONTACT: Au/Ni Ø.015 - Ø.020 [Ø.38 - Ø.51]

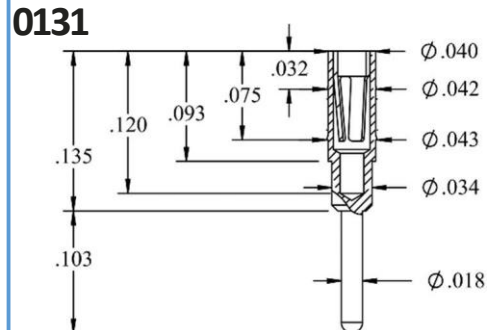

PLATING: Au/Ni CONTACT P/N: 0132  
SHELL: BeCu MATING PIN:  
CONTACT: Au/Ni Ø.015 - Ø.020 [Ø.38 - Ø.51]

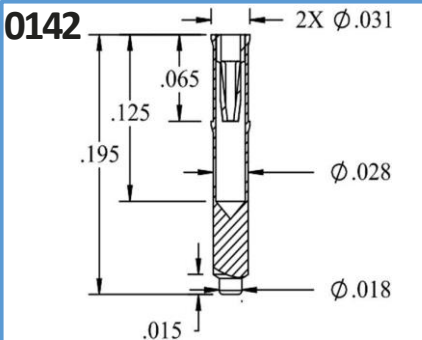

PLATING: Au/Ni CONTACT P/N: 0048  
SHELL: BeCu MATING PIN:  
CONTACT: Au/Ni Ø.007 - Ø.012 [Ø.18 - Ø.31]

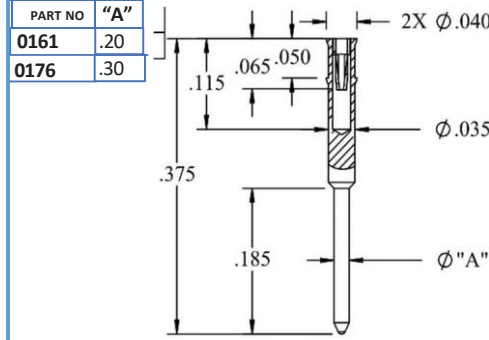

PLATING: Au/Ni CONTACT P/N: 0048  
SHELL: BeCu MATING PIN:  
CONTACT: Au/Ni Ø.007 - Ø.012 [Ø.18 - Ø.31]

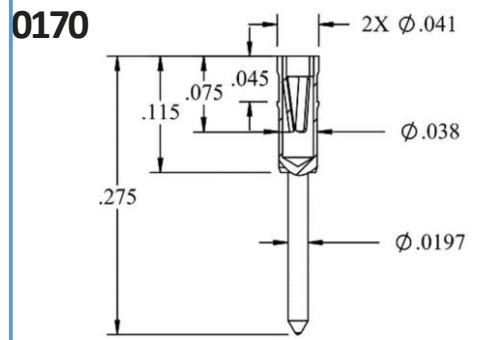

PLATING: Au/Ni CONTACT P/N: 0069  
SHELL: BeCu MATING PIN:  
CONTACT: Au/Ni Ø.015 - Ø.020 [Ø.38 - Ø.51]



### NOTES: UNLESS OTHERWISE SPECIFIED

#### SHELL / BODIES

#### MATERIAL \ FINISH

BRASS ALLOY C36000 per ASTM-B16, Half Hard plated Gold per MIL-G-45204 Type 2, Grade C, 10µ In. Min. over Nickel, 100µ In. Min. per QQ-N-290 Class 4. Or Tin per MIL-T-10727 Type I, 200µ In. Min. over Nickel 100µ In. Min.

#### CONTACTS

#### MATERIAL \ FINISH

Beryllium Copper, Alloy C17200 per ASTM-B194, heat treated, plated Gold per MIL-G-45204 Type 2, Grade C, Class 0, 30µIn. Min. or Class 00, 10µIn. Min., over Nickel per QQ-N-290 Class 4, 50µIn. Min. Or; Tin per MIL-T-10727 Type I, 200µIn. Min over Nickel, 50µIn. Min.

DIMENSIONS ARE IN INCHES

DIMENSIONAL TOLERANCES:

DRAWINGS NOT TO SCALE

DIAMETERS  
±.002

ANGLES  
±2°

LENGTHS  
±.005

**0177**

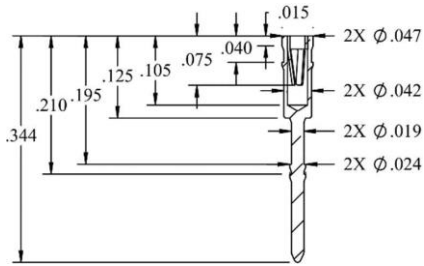

PLATING: Au/Ni CONTACT P/N: 0069  
SHELL: BeCu MATING PIN:  
CONTACT: Au/Ni Ø.007 - Ø.020 [Ø.38 - Ø.51]

**0191**

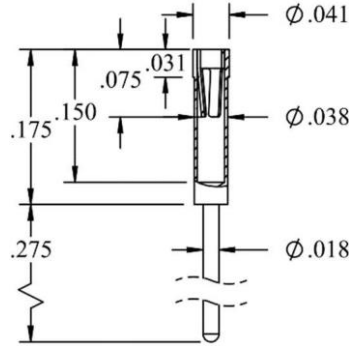

PLATING: Au/Ni CONTACT P/N: 0132  
SHELL: BeCu MATING PIN:  
CONTACT: Au/Ni Ø.015 - Ø.020 [Ø.38 - Ø.51]

**0357**

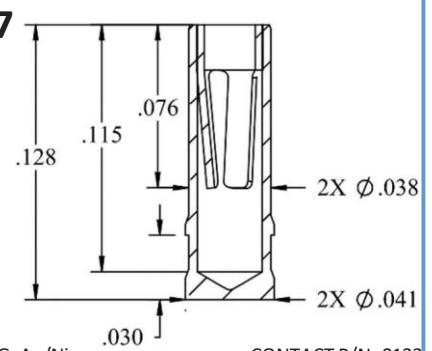

PLATING: Au/Ni CONTACT P/N: 0132  
SHELL: BeCu MATING PIN:  
CONTACT: Au/Ni Ø.015 - Ø.020 [Ø.38 - Ø.51]

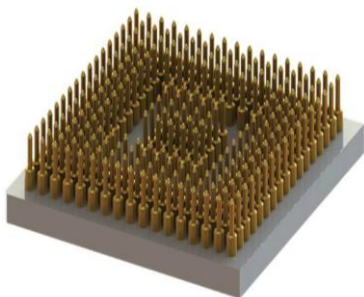

**NOTES: UNLESS OTHERWISE SPECIFIED**

SHELL / BODIES

MATERIAL \ FINISH

BRASS ALLOY C36000 per ASTM-B16, Half Hard plated Gold per MIL-G-45204 Type 2, Grade C, 10µ In. Min. over Nickel, 100µ In. Min. per QQ-N-290 Class 4. Or Tin per MIL-T-10727 Type I, 200µ In. Min. over Nickel 100µ In. Min.

CONTACTS

MATERIAL \ FINISH

Beryllium Copper, Alloy C17200 per ASTM-B194, heat treated, plated Gold per MIL-G-45204 Type 2, Grade C, Class 0, 30µIn. Min. or Class 00, 10µIn. Min., over Nickel per QQ-N-290 Class 4, 50µIn. Min. Or; Tin per MIL-T-10727 Type I, 200µIn. Min over Nickel, 50µIn. Min.

DIMENSIONS ARE IN INCHES

DIMENSIONAL TOLERANCES:

DRAWINGS NOT TO SCALE

DIAMETERS  
±.002

ANGLES  
±2°

LENGTHS  
±.005

# SOCKET PINS

## FOR Ø0.015 ~ Ø0.035 PINS



PART NO	SHELL
0001	Pure Tin
0002	Tin Plated
0005	Gold/Nickel

PLATING: Au/Ni CONTACT P/N: 0072  
SHELL: See Table MATING PIN:  
CONTACT: Sn/Ni Ø.025 - Ø.035 [Ø.64 - Ø.89]

### 0026

PLATING: Au/Ni CONTACT P/N: 0286  
SHELL: BeCu MATING PIN:  
CONTACT: Au/Ni Ø.015 - Ø.021 [Ø.38 - Ø.53]

### 0032

PLATING: Au/Ni CONTACT P/N: 0072  
SHELL: BeCu MATING PIN:  
CONTACT: Au/Ni Ø.015 - Ø.022 [Ø.38 - Ø.56]

### 0033

PLATING: Au/Ni CONTACT P/N: 0284  
SHELL: BeCu MATING PIN:  
CONTACT: Au/Ni Ø.015 - Ø.022 [Ø.38 - Ø.56]

### 0066

PLATING: Au/Ni CONTACT P/N: 0284  
SHELL: BeCu MATING PIN:  
CONTACT: Au/Ni Ø.025 - Ø.034 [Ø.64 - Ø.86]

### 0090

PLATING: Au/Ni CONTACT P/N: 0141  
SHELL: BeCu MATING PIN:  
CONTACT: Au/Ni Ø.015 - Ø.026 [Ø.38 - Ø.66]

### 0187

PLATING: Au/Ni CONTACT P/N: 0284  
SHELL: BeCu MATING PIN:  
CONTACT: Au/Ni Ø.025 - Ø.034 [Ø.64 - Ø.86]

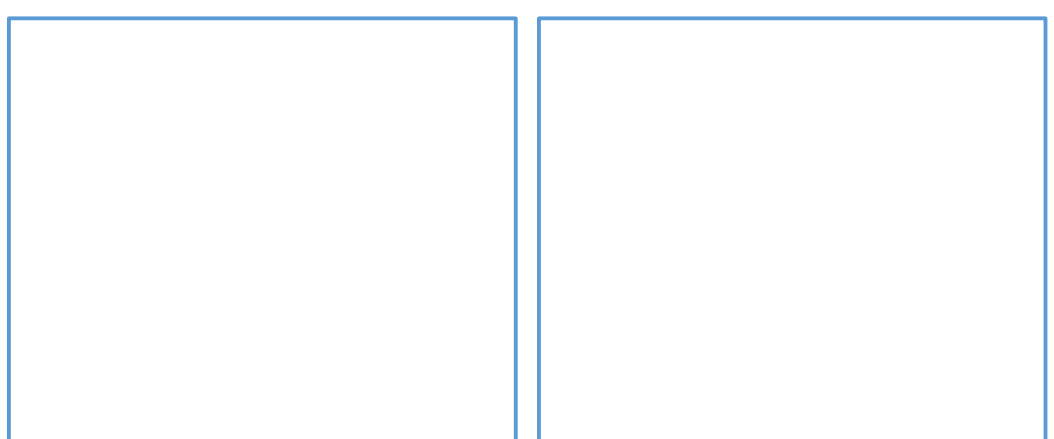

**NOTES: UNLESS OTHERWISE SPECIFIED**

**SHELL / BODIES**  
MATERIAL \ FINISH  
BRASS ALLOY C36000 per ASTM-B16, Half Hard plated Gold per MIL-G-45204 Type 2, Grade C, 10µIn. Min. over Nickel, 100µ In. Min. per QQ-N-290 Class 4. Or Tin per MIL-T-10727 Type I, 200µ In. Min. over Nickel 100µ In. Min.

**CONTACTS**  
MATERIAL \ FINISH  
Beryllium Copper, Alloy C17200 per ASTM-B194, heat treated, plated Gold per MIL-G-45204 Type 2, Grade C, Class 0, 30µIn. Min. or Class 00, 10µIn. Min., over Nickel per QQ-N-290 Class 4, 50µIn. Min. Or; Tin per MIL-T-10727 Type I, 200µIn. Min over Nickel, 50µIn. Min.

DIMENSIONS ARE IN INCHES DIMENSIONAL TOLERANCES: DRAWINGS NOT TO SCALE  
DIAMETERS ±.002 ANGLES ±2° LENGTHS ±.005

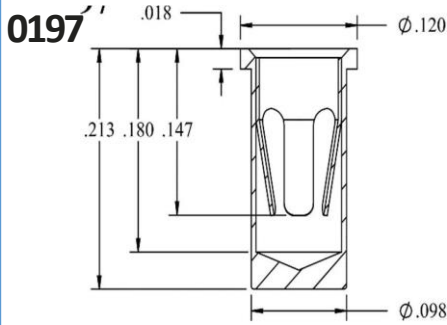

PLATING: Au/Ni  
SHELL: BeCu  
CONTACT: Au/Ni

CONTACT P/N: 0291  
MATING PIN:  
Ø.040 - Ø.059 [Ø1.07 - Ø1.50]

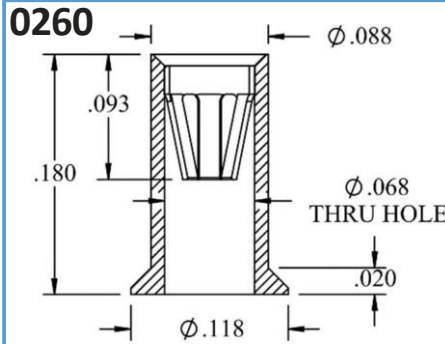

PLATING: Au/Ni  
SHELL: BeCu  
CONTACT: Au/Ni

CONTACT P/N: 0248  
MATING PIN:  
Ø.040 - Ø.050 [Ø1.02 - Ø1.27]

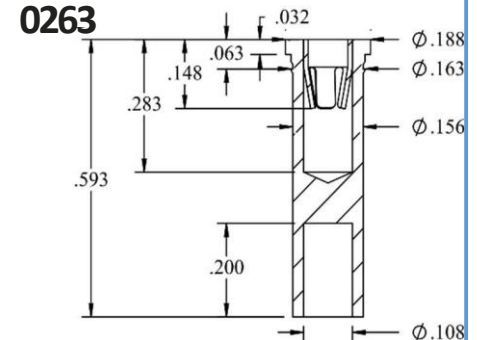

PLATING: Au/Ni  
SHELL: BeCu  
CONTACT: Au/Ni

CONTACT P/N: 0291  
MATING PIN:  
Ø.040 - Ø.059 [Ø1.07 - Ø1.50]

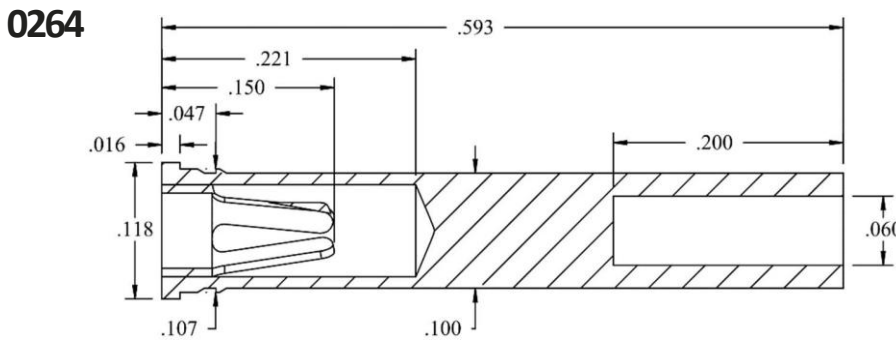

PLATING: Au/Ni  
SHELL: BeCu  
CONTACT: Au/Ni

CONTACT P/N: 0291  
MATING PIN:  
Ø.040 - Ø.059 [Ø1.07 - Ø1.50]

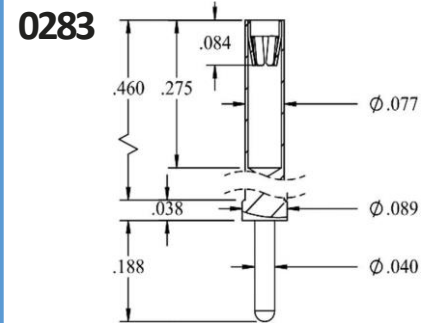

PLATING: Au/Ni  
SHELL: BeCu  
CONTACT: Au/Ni

CONTACT P/N: 0248  
MATING PIN:  
Ø.040 - Ø.050 [Ø1.02 - Ø1.27]

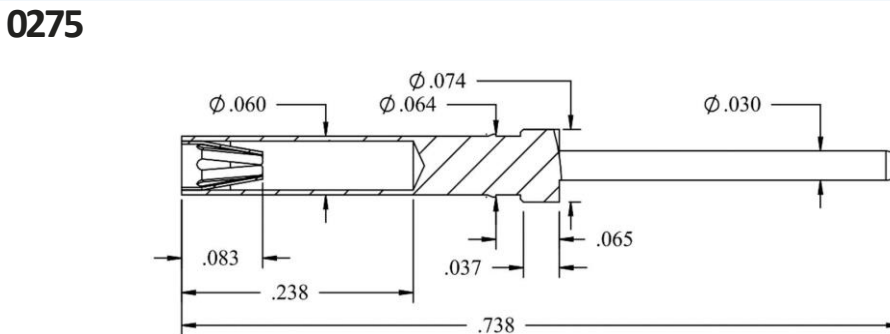

PLATING: Au/Ni  
SHELL: BeCu  
CONTACT: Au/Ni

CONTACT P/N: 0284  
MATING PIN:  
Ø.025 - Ø.035 [Ø.64 - Ø.89]

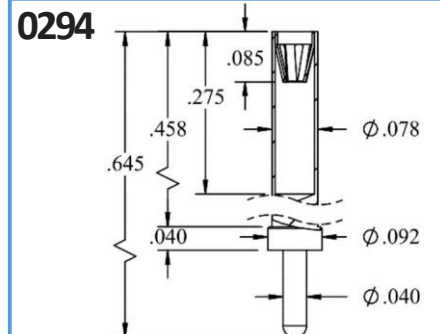

PLATING: Au/Ni  
SHELL: BeCu  
CONTACT: Au/Ni

CONTACT P/N: 0248  
MATING PIN:  
Ø.040 - Ø.050 [Ø1.02 - Ø1.27]

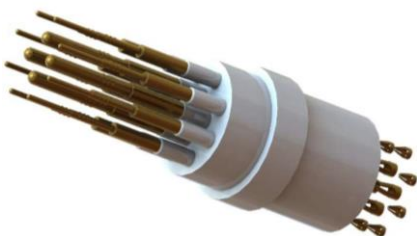

**NOTES: UNLESS OTHERWISE SPECIFIED**

**SHELL / BODIES**  
MATERIAL \ FINISH  
BRASS ALLOY C36000 per ASTM-B16, Half Hard  
plated Gold per MIL-G-45204 Type 2, Grade C,  
10µ In. Min. over Nickel, 100µ In. Min, per QQ-  
N-290 Class 4. Or Tin per MIL-T-10727 Type I,  
200µ In. Min. over Nickel 100µ In. Min.

**CONTACTS**  
MATERIAL \ FINISH  
Beryllium Copper, Alloy C17200 per ASTM-B194,  
heat treated, plated Gold per MIL-G-45204 Type  
2, Grade C, Class 0, 30µIn. Min. or Class 00,  
10µIn. Min., over Nickel per QQ-N-290 Class 4,  
50µIn. Min. Or; Tin per MIL-T-10727 Type I,  
200µIn. Min over Nickel, 50µIn. Min.

DIMENSIONS ARE IN INCHES

DIMENSIONAL TOLERANCES:

DRAWINGS NOT TO SCALE

DIAMETERS  
±.002

ANGLES  
±2°

LENGTHS  
±.005

**0346**

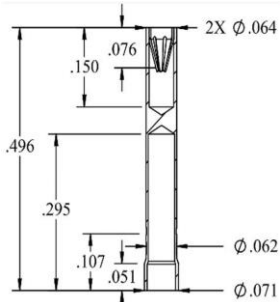

PLATING: Au/Ni CONTACT P/N: 0043  
SHELL: BeCu MATING PIN:  
CONTACT: Au/Ni Ø.025 - Ø.037 [Ø.64 - Ø.90]

**0347**

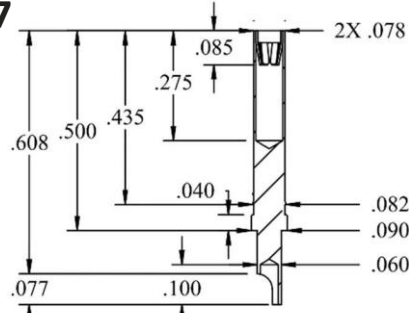

PLATING: Au/Ni CONTACT P/N: 0248  
SHELL: BeCu MATING PIN:  
CONTACT: Au/Ni Ø.040 - Ø.050 [Ø1.02 - Ø1.27]

**0359**

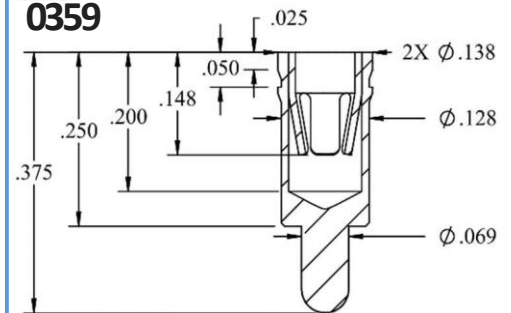

PLATING: Sn/Ni CONTACT P/N: 0292  
SHELL: BeCu MATING PIN:  
CONTACT: Au/Ni Ø.065 - Ø.082 [Ø1.65 - Ø2.08]

**0361**

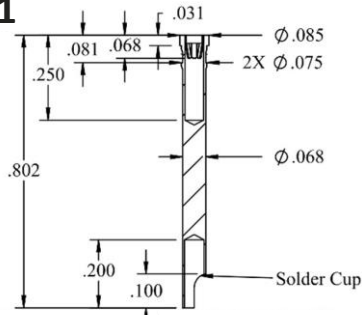

PLATING: Au/Ni CONTACT P/N: 0366  
SHELL: BeCu MATING PIN:  
CONTACT: Au/Ni Ø.037 - Ø.043 [Ø.94 - Ø1.09]

PART NO	"A"
0362	.702
0393	.782

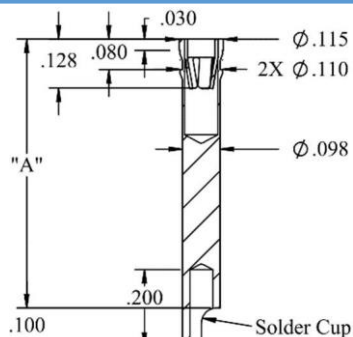

PLATING: Au/Ni CONTACT P/N: 0365  
SHELL: BeCu MATING PIN:  
CONTACT: Au/Ni Ø.048 - Ø.064 [Ø1.22 - Ø1.63]

**0377**

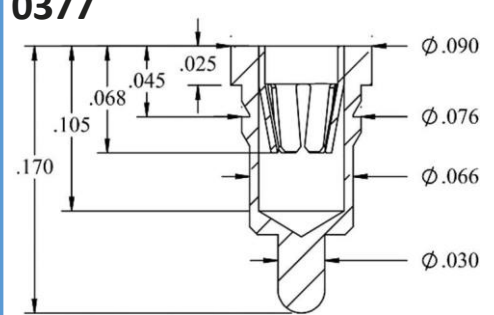

PLATING: Sn/Ni  
SHELL: BeCu  
CONTACT: Au/Ni

**0617**

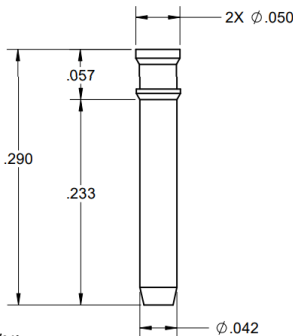

PLATING: Au/Ni  
SHELL: BeCu  
CONTACT: Au/Ni

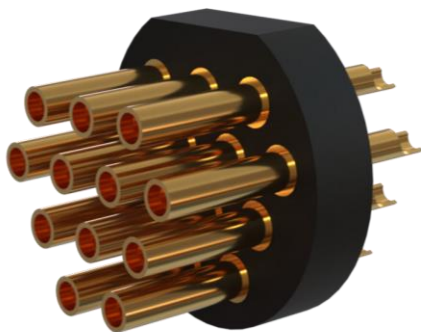

**NOTES: UNLESS OTHERWISE SPECIFIED**

SHELL / BODIES

MATERIAL \ FINISH  
BRASS ALLOY C36000 per ASTM-B16, Half Hard  
plated Gold per MIL-G-45204 Type 2, Grade C,  
10µ In. Min. over Nickel, 100µ In. Min. per QQ-  
N-290 Class 4. Or Tin per MIL-T-10727 Type I,  
200µ In. Min. over Nickel 100µ In. Min.

CONTACTS

MATERIAL \ FINISH

Beryllium Copper, Alloy C17200 per ASTM-B194,  
heat treated, plated Gold per MIL-G-45204 Type  
2, Grade C, Class 0, 30µIn. Min. or Class 00,  
10µIn. Min., over Nickel per QQ-N-290 Class 4,  
50µIn. Min. Or; Tin per MIL-T-10727 Type I,  
200µIn. Min over Nickel, 50µIn. Min.

DIMENSIONS ARE IN INCHES

DIMENSIONAL TOLERANCES:

DRAWINGS NOT TO SCALE

DIAMETERS  
±.002

ANGLES  
±2°

LENGTHS  
±.005

**0006**

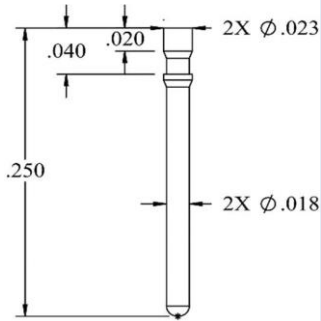

PLATING: Au/Ni  
SHELL: BeCu

**0009**

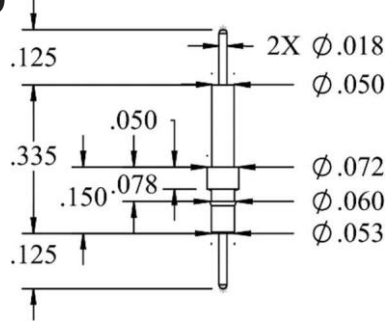

PLATING: Au/Ni  
SHELL: BeCu

**0026**

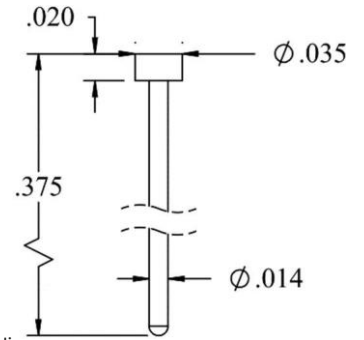

PLATING: Au/Ni  
SHELL: BeCu

PART NO	DIM"A"	DIM"B"	PLATING
0013	.200	.060	Sn/Ni
0070	.260	.070	Sn/Ni
0021	.303	.060	Sn/Ni
0022	.200	.060	Au/Ni

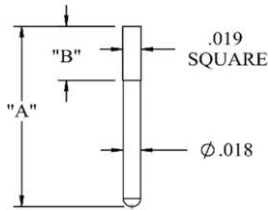

PLATING: See Table  
SHELL: See Table

**0015**

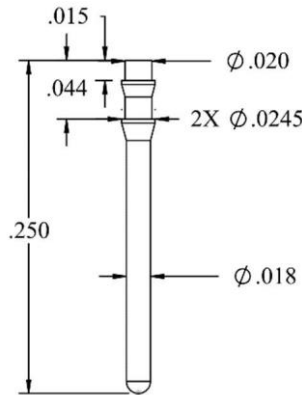

PLATING: Au/Ni  
SHELL: BeCu

**0025**

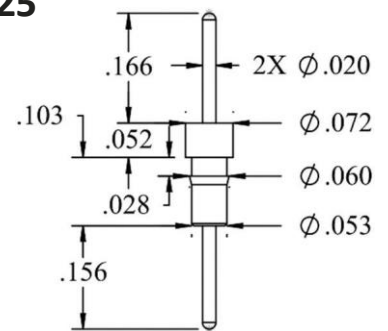

PLATING: Sn/Ni  
SHELL: BeCu

**0028**

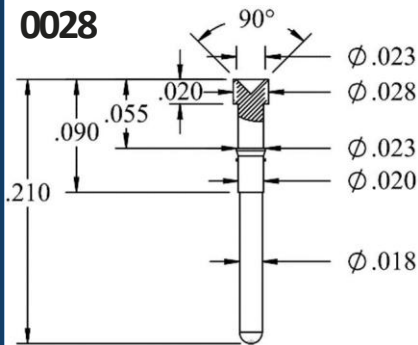

PLATING: Au/Ni  
SHELL: BeCu

**0039**

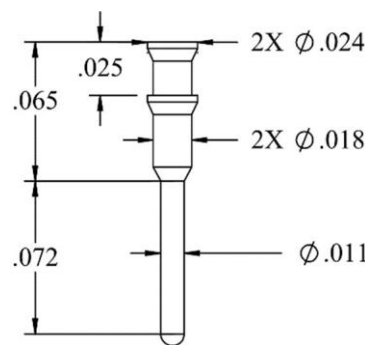

PLATING: Au/Ni  
SHELL: BeCu

**0040**

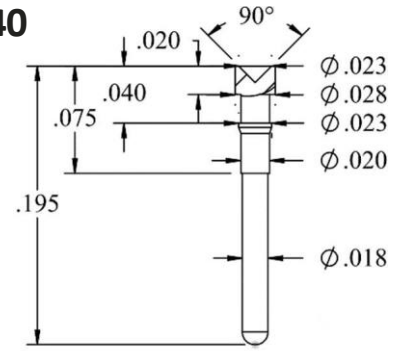

PLATING: Au/Ni  
SHELL: BeCu

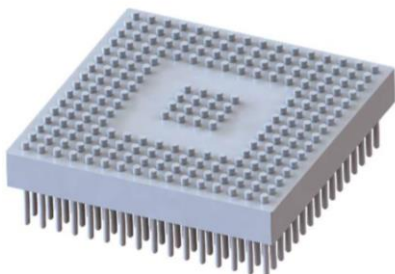

**NOTES: UNLESS OTHERWISE SPECIFIED**

SHELL / BODIES

MATERIAL \ FINISH

BRASS ALLOY C36000 per ASTM-B16, Half Hard plated Gold per MIL-G-45204 Type 2, Grade C, 10µ In. Min. over Nickel, 100µ In. Min, per QQ-N-290 Class 4. Or Tin per MIL-T-10727 Type I, 200µ In. Min. over Nickel 100µ In. Min.

DIMENSIONS ARE IN INCHES

DIMENSIONAL TOLERANCES:

DRAWINGS NOT TO SCALE

DIAMETERS  
±.002

ANGLES  
±2°

LENGTHS  
±.005

**0041**

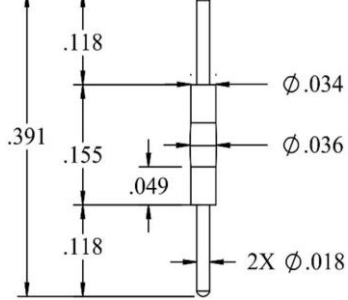

PLATING: Au/Ni  
SHELL: BeCu

**0058**

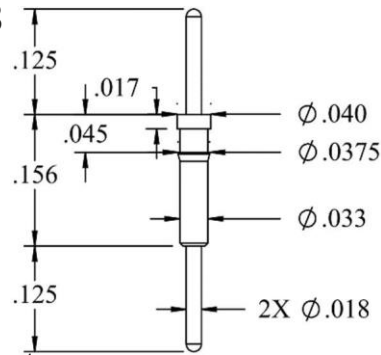

PLATING: Au/Ni  
SHELL: BeCu

**0064**

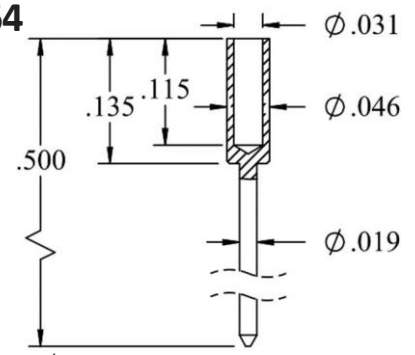

PLATING: Au/Ni  
SHELL: BeCu

**0076**

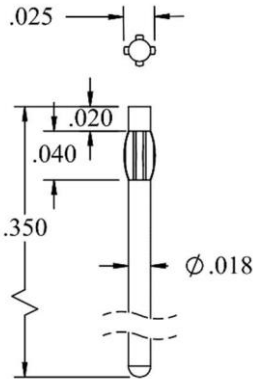

PLATING: Au/Ni  
SHELL: BeCu

**0084**

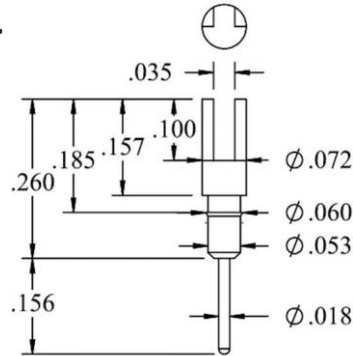

PLATING: Sn/Ni  
SHELL: BeCu

PART NO	"A"
0087	.650
0088	.500

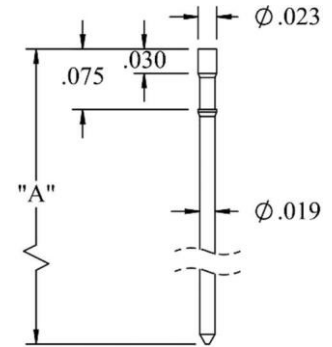

PLATING: Au/Ni  
SHELL: BeCu

**0089**

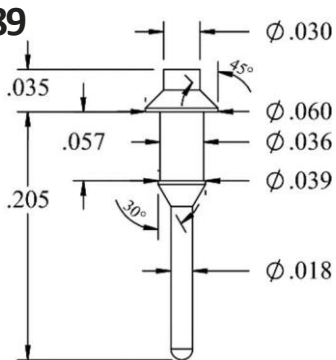

PLATING: Au/Ni  
SHELL: BeCu

PART NO	"A"
0091	.119
0246.B	.129

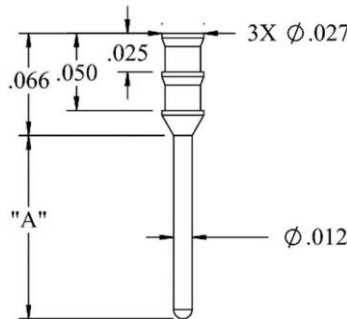

PLATING: Au/Ni  
SHELL: BeCu

**0095**

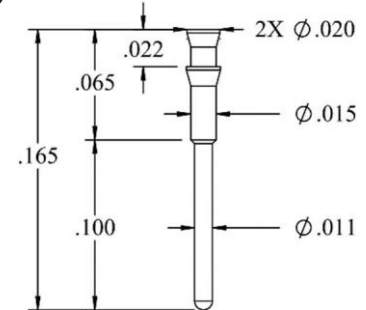

PLATING: Au/Ni  
SHELL: BeCu

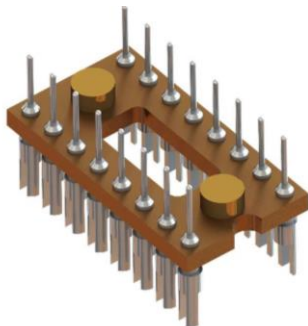

**NOTES: UNLESS OTHERWISE SPECIFIED**

SHELL / BODIES

MATERIAL \ FINISH

BRASS ALLOY C36000 per ASTM-B16, Half Hard plated Gold per MIL-G-45204 Type 2, Grade C, 10 $\mu$  In. Min. over Nickel, 100 $\mu$  In. Min. per QQ-N-290 Class 4. Or Tin per MIL-T-10727 Type I, 200 $\mu$  In. Min. over Nickel 100 $\mu$  In. Min.

DIMENSIONS ARE IN INCHES

DIAMETERS  
 $\pm .002$

DIMENSIONAL TOLERANCES:

ANGLES  
 $\pm 2^\circ$

DRAWINGS NOT TO SCALE

LENGTHS  
 $\pm .005$

**0097**

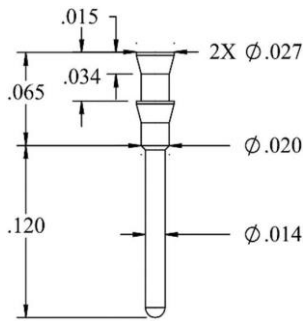

PLATING: Au/Ni  
SHELL: BeCu

**0102**

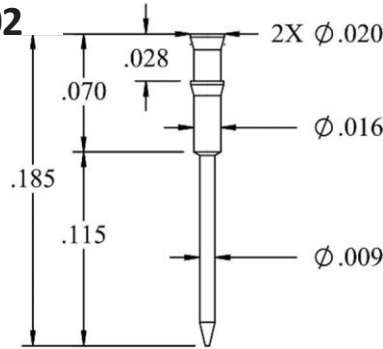

PLATING: Au/Ni  
SHELL: BeCu

**0105**

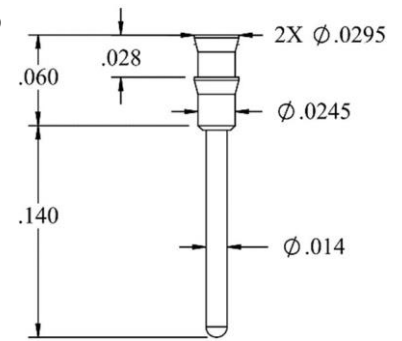

PLATING: Au/Ni  
SHELL: BeCu

**0108**

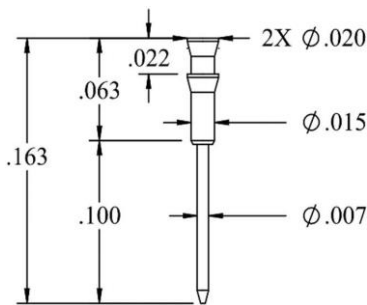

PLATING: Au/Ni  
SHELL: BeCu

PART NO	"A"	"B"	"C"
0134	.046	.042	.047
0135	.032	.028	.045

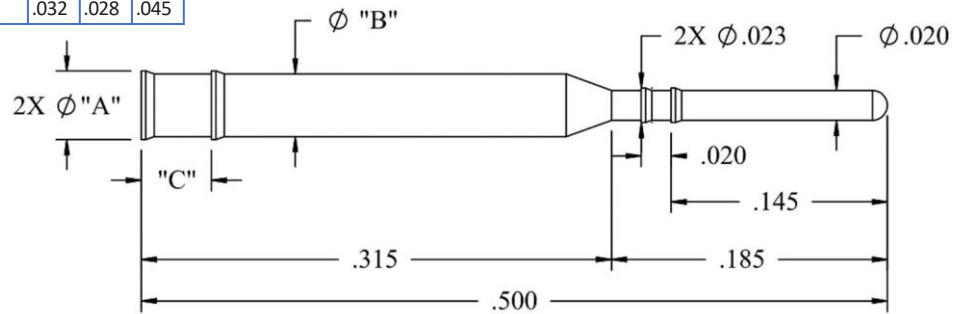

PLATING: Au/Ni  
SHELL: BeCu

**0164**

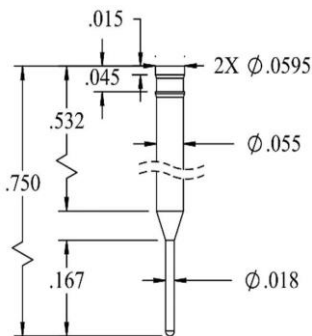

PLATING: Au/Ni  
SHELL: BeCu

**0165**

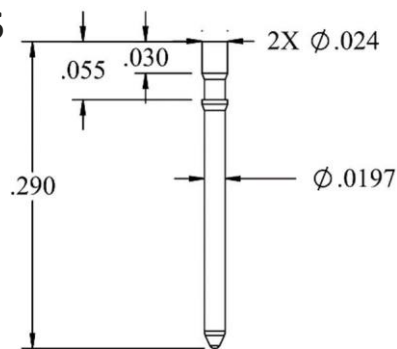

PLATING: Au/Ni  
SHELL: BeCu

**0173**

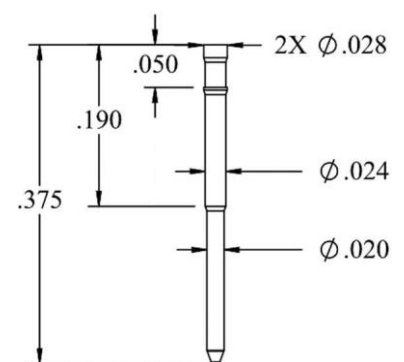

PLATING: Au/Ni  
SHELL: BeCu



**NOTES: UNLESS OTHERWISE SPECIFIED**

SHELL / BODIES

MATERIAL \ FINISH

BRASS ALLOY C36000 per ASTM-B16, Half Hard plated Gold per MIL-G-45204 Type 2, Grade C, 10µ In. Min. over Nickel, 100µ In. Min. per QQ-N-290 Class 4. Or Tin per MIL-T-10727 Type I, 200µ In. Min. over Nickel 100µ In. Min.

DIMENSIONS ARE IN INCHES

DIMENSIONAL TOLERANCES:

DRAWINGS NOT TO SCALE

DIAMETERS  
±.002

ANGLES  
±2°

LENGTHS  
±.005

### 0175

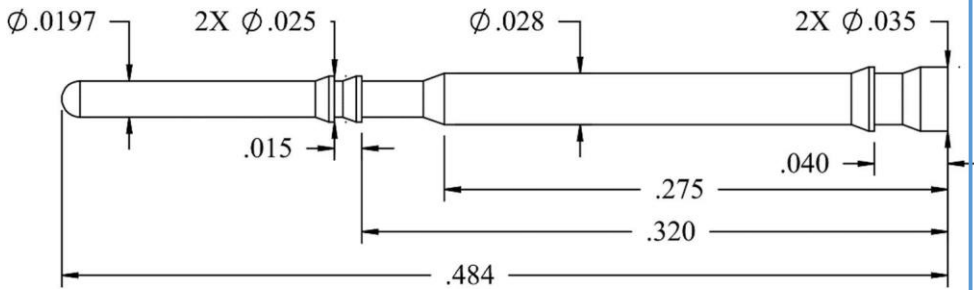

PLATING: Au/Ni  
SHELL: BeCu

### 0179

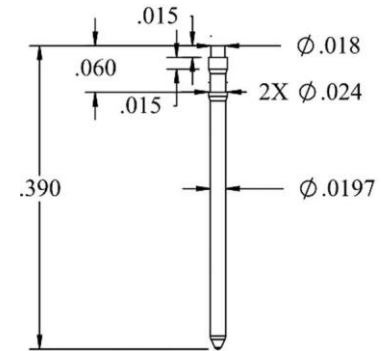

PLATING: Au/Ni  
SHELL: BeCu

### 0178

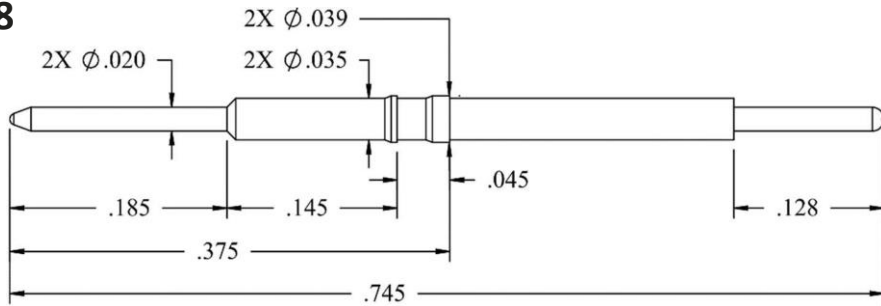

PLATING: Au/Ni SHELL:  
BeCu

### 0181

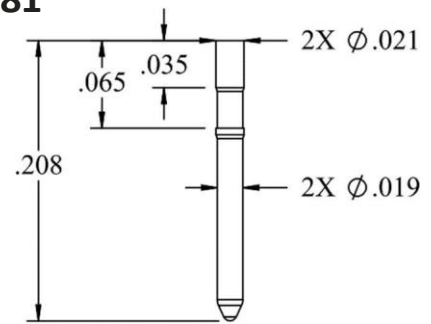

PLATING: Au/Ni  
SHELL: BeCu

### 0184

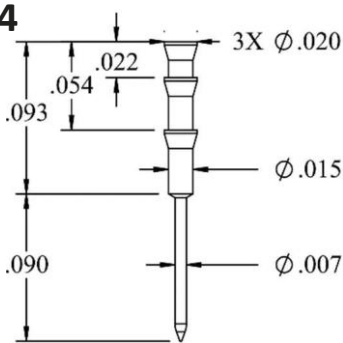

PLATING: Au/Ni  
SHELL: BeCu

### 0186

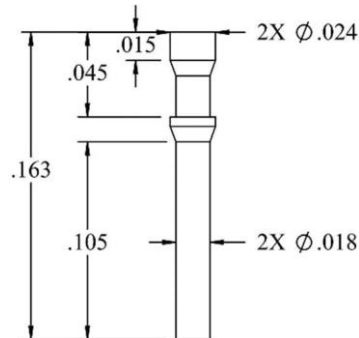

PLATING: Au/Ni  
SHELL: BeCu

### 0220

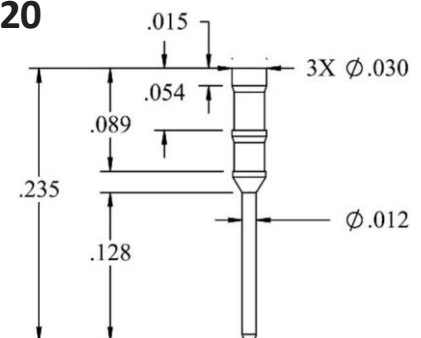

PLATING: Au/Ni  
SHELL: BeCu

#### NOTES: UNLESS OTHERWISE SPECIFIED

##### SHELL / BODIES

##### MATERIAL \ FINISH

BRASS ALLOY C36000 per ASTM-B16, Half Hard plated Gold per MIL-G-45204 Type 2, Grade C, 10 $\mu$  In. Min. over Nickel, 100 $\mu$  In. Min, per QQ-N-290 Class 4. Or Tin per MIL-T-10727 Type I, 200 $\mu$  In. Min. over Nickel 100 $\mu$  In. Min.

DIMENSIONS ARE IN INCHES  
DIAMETERS  
 $\pm 0.02$

DIMENSIONAL TOLERANCES:  
ANGLES  
 $\pm 2^\circ$

DRAWINGS NOT TO SCALE  
LENGTHS  
 $\pm 0.05$



### 0223

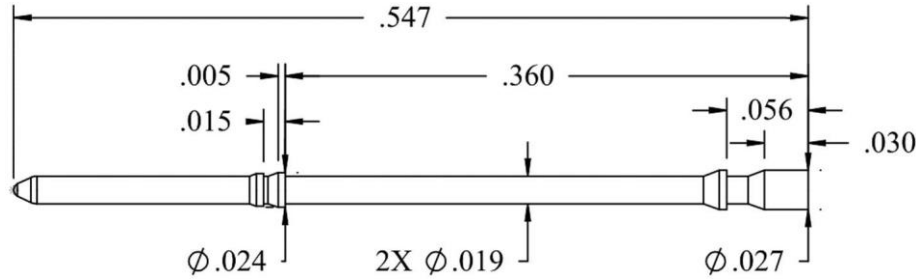

PLATING: Au/Ni  
SHELL: BeCu

PART NO	Ø"A"	Ø"B"
0237	.016	.013
0238	.024	.020

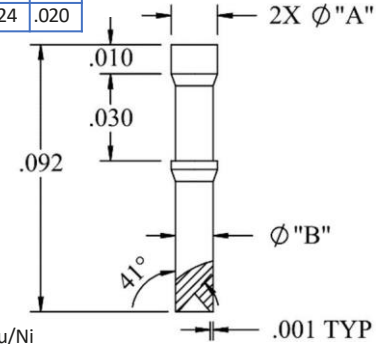

PLATING: Au/Ni  
SHELL: BeCu

PART NO	Ø"A"	Ø"B"
0240	.016	.013
0241	.024	.020

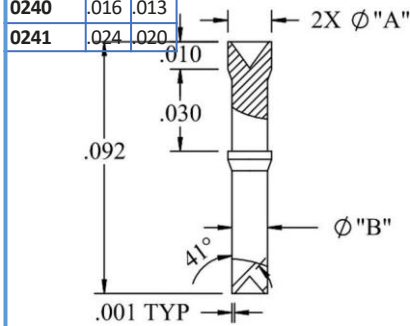

PLATING: Au/Ni  
SHELL: BeCu

PART NO	Ø"A"	Ø"B"
0242	.016	.013
0243	.024	.020

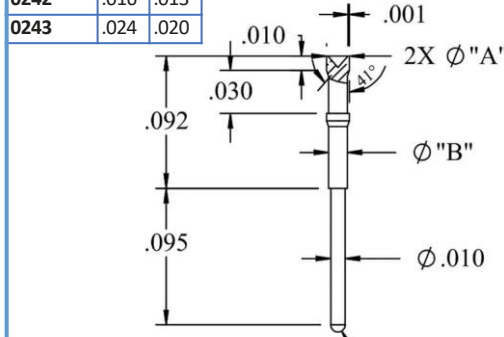

PLATING: Au/Ni  
SHELL: BeCu

### 0244

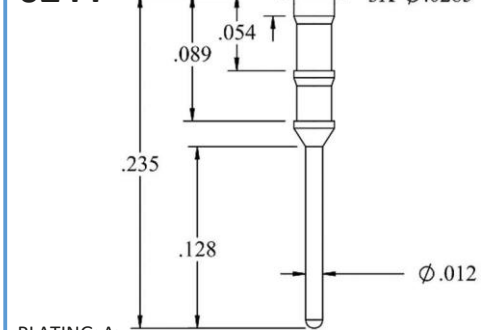

PLATING: Au/Ni  
SHELL: BeCu

### 0246.C

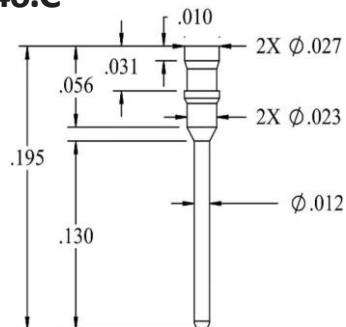

PLATING: Au/Ni  
SHELL: BeCu

### 0253

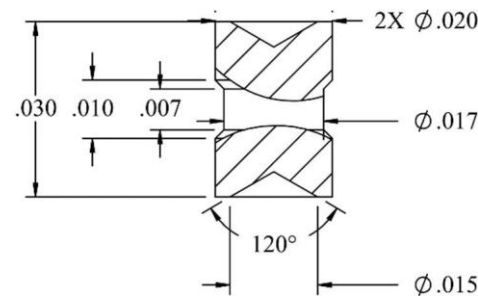

PLATING: Au/Ni  
SHELL: BeCu

### 0267

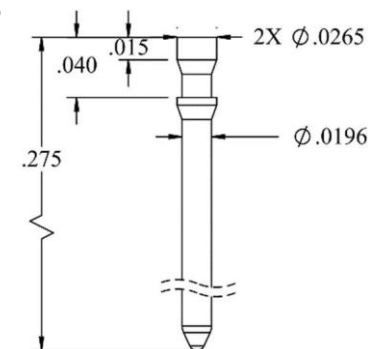

PLATING: Au/Ni  
SHELL: BeCu

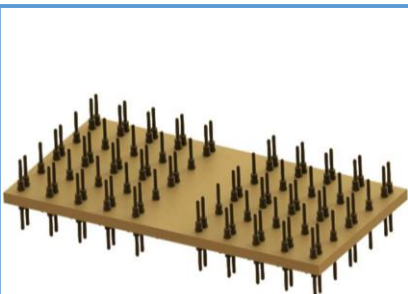

#### NOTES: UNLESS OTHERWISE SPECIFIED

##### SHELL / BODIES

##### MATERIAL \ FINISH

BRASS ALLOY C36000 per ASTM-B16, Half Hard plated Gold per MIL-G-45204 Type 2, Grade C, 10µ In. Min. over Nickel, 100µ In. Min. per QQ-N-290 Class 4. Or Tin per MIL-T-10727 Type I, 200µ In. Min. over Nickel 100µ In. Min.

DIMENSIONS ARE IN INCHES  
DIAMETERS  
±.002

DIMENSIONAL TOLERANCES:  
ANGLES  
±2°

DRAWINGS NOT TO SCALE  
LENGTHS  
±.005

### 0268

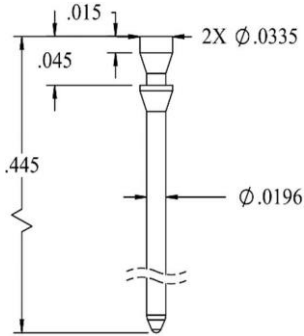

PLATING: Au/Ni  
SHELL: BeCu

### 0269

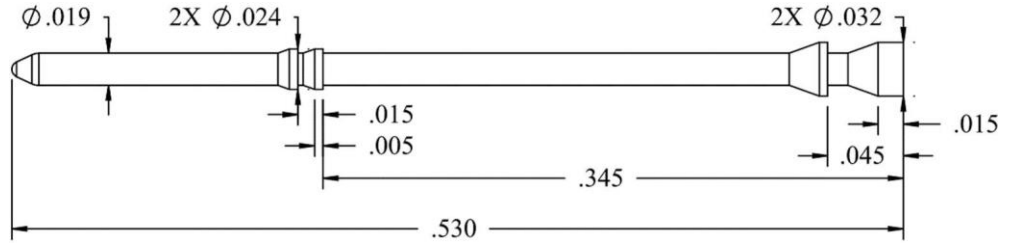

PLATING: Au/Ni  
SHELL: BeCu

PART NO	Ø"A"	Ø"B"
0287	.033	.130
0290	.053	.145
0302	.033	.145

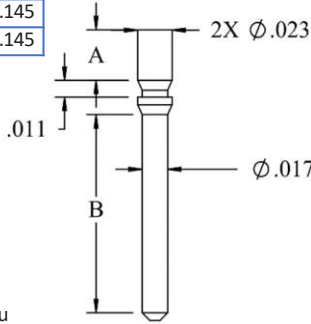

PLATING: Au/Ni  
SHELL: BeCu

PART NO	Ø"A"	Ø"B"
0288	.033	.090
0289	.053	.114
0301	.033	.115

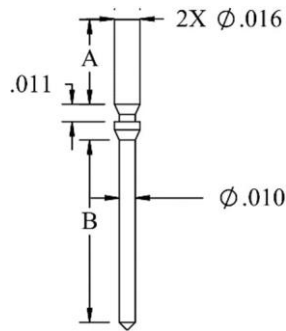

PLATING: Au/Ni  
SHELL: BeCu

### 0352

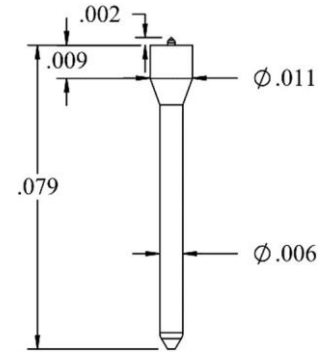

PLATING: Au/Ni  
SHELL: BeCu

### 0371

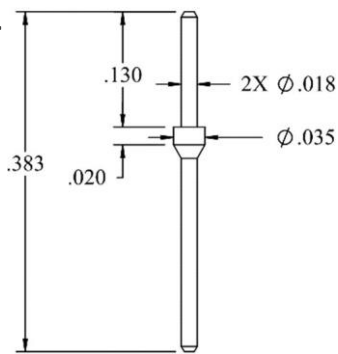

PLATING: Sn/Ni  
SHELL: BeCu

### 0372

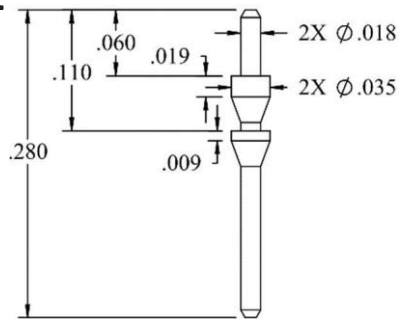

PLATING: Sn/Ni  
SHELL: BeCu

### 0373

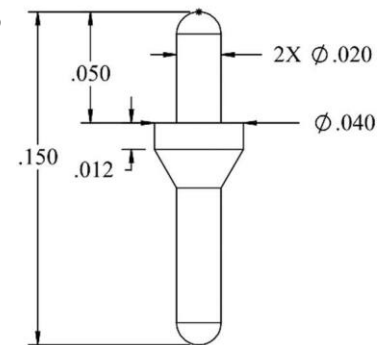

PLATING: Au/Ni  
SHELL: BeCu

#### NOTES: UNLESS OTHERWISE SPECIFIED

##### SHELL / BODIES

##### MATERIAL \ FINISH

BRASS ALLOY C36000 per ASTM-B16, Half Hard plated Gold per MIL-G-45204 Type 2, Grade C, 10µ In. Min. over Nickel, 100µ In. Min. per QQ-N-290 Class 4. Or Tin per MIL-T-10727 Type I, 200µ In. Min. over Nickel 100µ In. Min.

DIMENSIONS ARE IN INCHES

DIMENSIONAL TOLERANCES:  
LENGTHS ±.005    DIAMETERS ±.002    ANGLES ±2°

DRAWINGS NOT TO SCALE

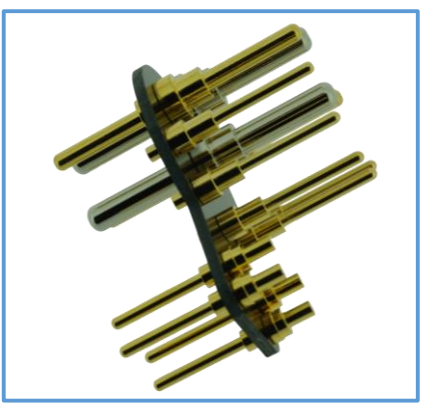
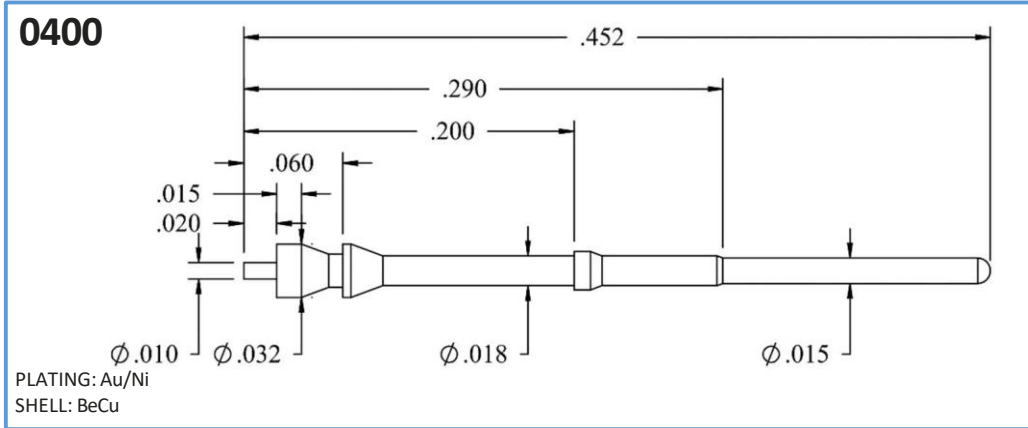
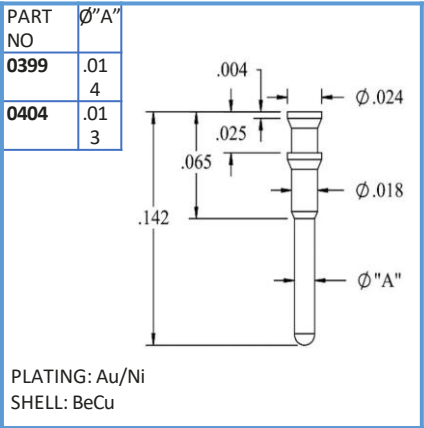
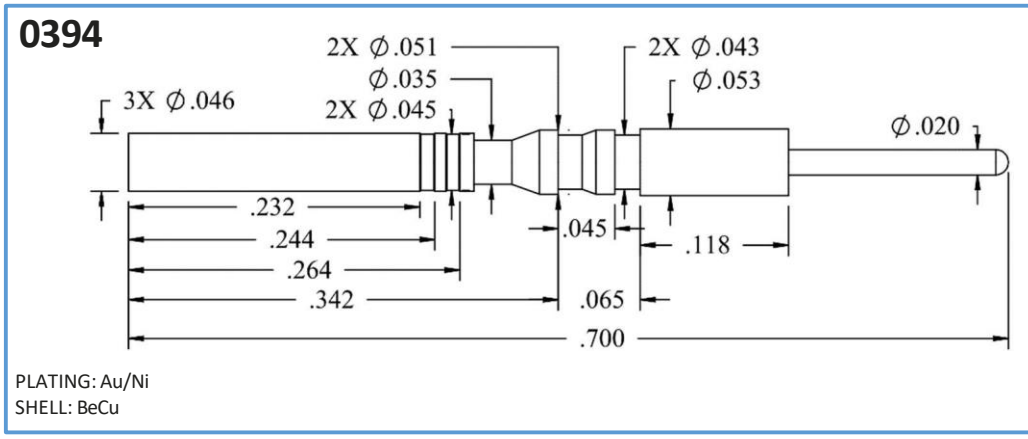
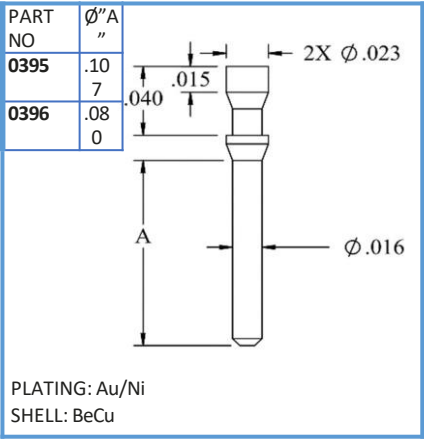
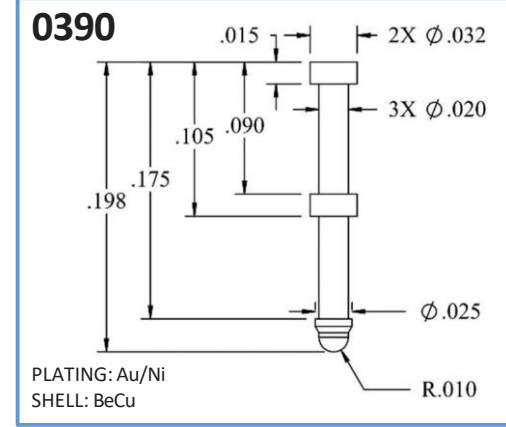
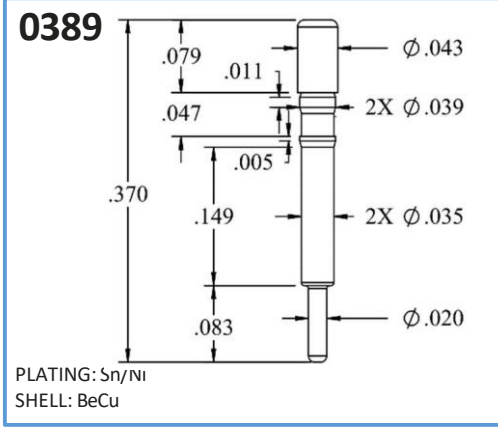
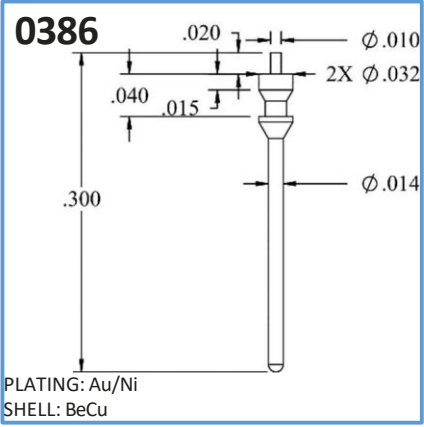

**NOTES: UNLESS OTHERWISE SPECIFIED**

SHELL / BODIES  
MATERIAL \ FINISH  
BRASS ALLOY C36000 per ASTM-B16, Half Hard plated Gold per MIL-G-45204 Type 2, Grade C, 10 $\mu$  In. Min. over Nickel, 100 $\mu$  In. Min. per QQ-N-290 Class 4. Or Tin per MIL-T-10727 Type I, 200 $\mu$  In. Min. over Nickel 100 $\mu$  In. Min.

DIMENSIONS ARE IN INCHES      DIMENSIONAL TOLERANCES:      DRAWINGS NOT TO SCALE  
LENGTHS      DIAMETERS      ANGLES  
 $\pm .005$        $\pm .002$        $\pm 2^\circ$

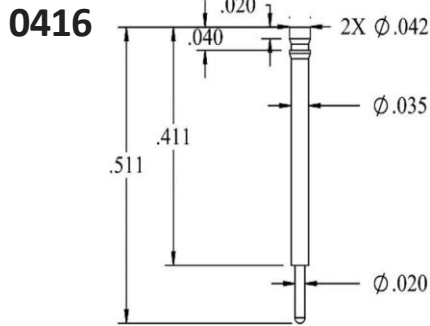

PLATING: Sn/Ni  
SHELL: BeCu

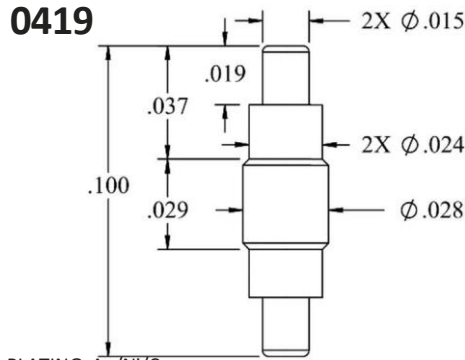

PLATING: Au/Ni/Cu  
SHELL: BeCu

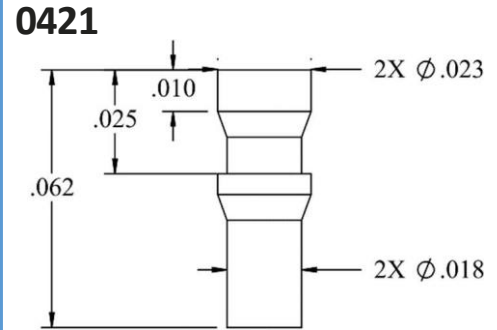

PLATING: Sn/Ni/Cu  
SHELL: BeCu

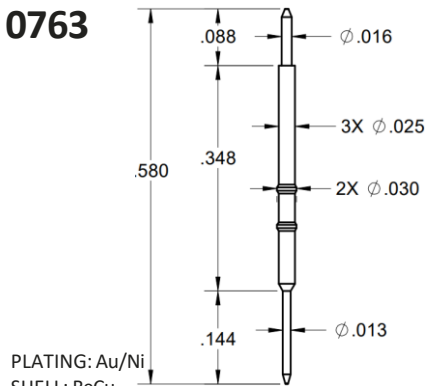

PLATING: Au/Ni  
SHELL: BeCu

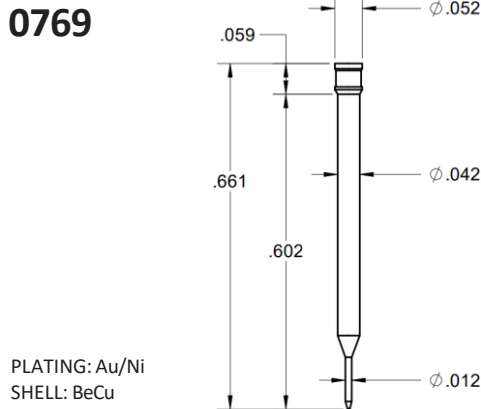

PLATING: Au/Ni  
SHELL: BeCu

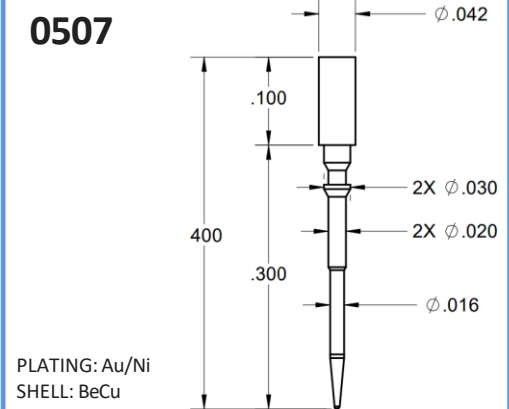

PLATING: Au/Ni  
SHELL: BeCu

### NOTES: UNLESS OTHERWISE SPECIFIED

#### SHELL / BODIES

#### MATERIAL \ FINISH

BRASS ALLOY C36000 per ASTM-B16, Half Hard plated Gold per MIL-G-45204 Type 2, Grade C, 10 $\mu$  In. Min. over Nickel, 100 $\mu$  In. Min. per QQ-N-290 Class 4. Or Tin per MIL-T-10727 Type I, 200 $\mu$  In. Min. over Nickel 100 $\mu$  In. Min.

DIMENSIONS ARE IN INCHES

DIMENSIONAL TOLERANCES:  
LENGTHS  $\pm 0.005$  DIAMETERS  $\pm 0.002$  ANGLES  $\pm 2^\circ$

DRAWINGS NOT TO SCALE

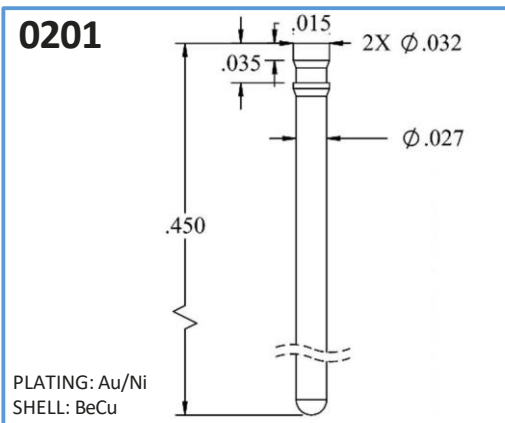
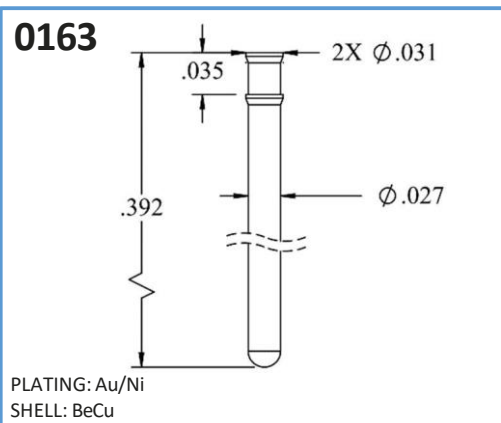
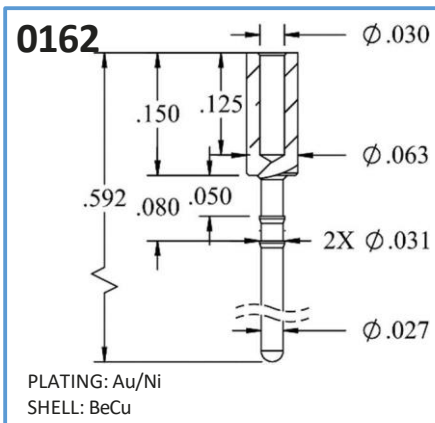
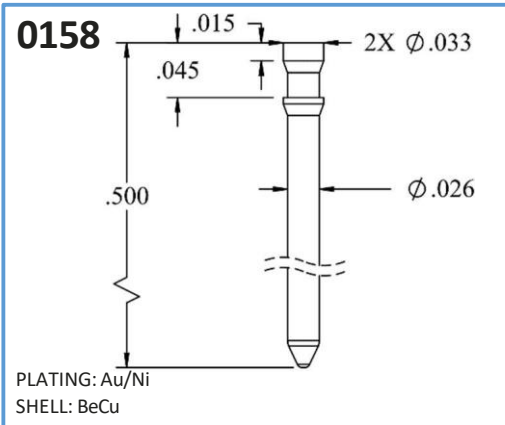
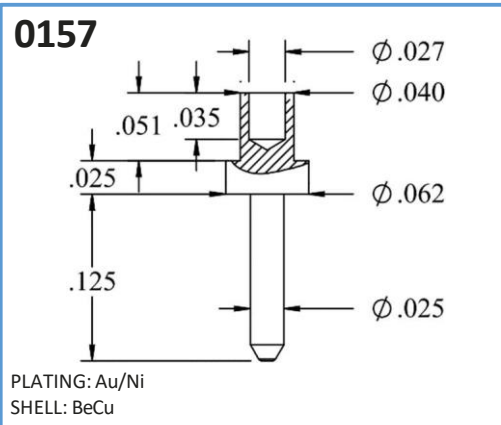
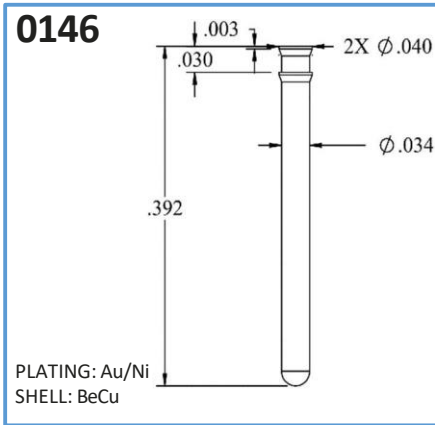
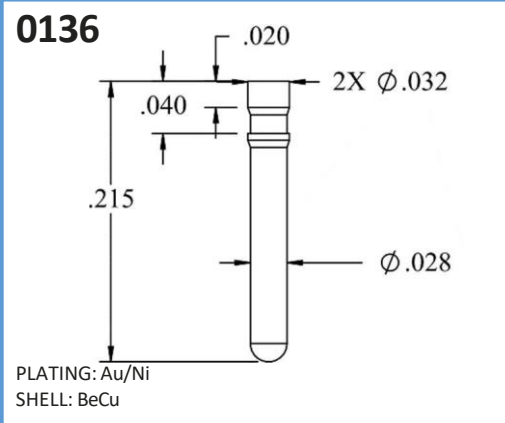
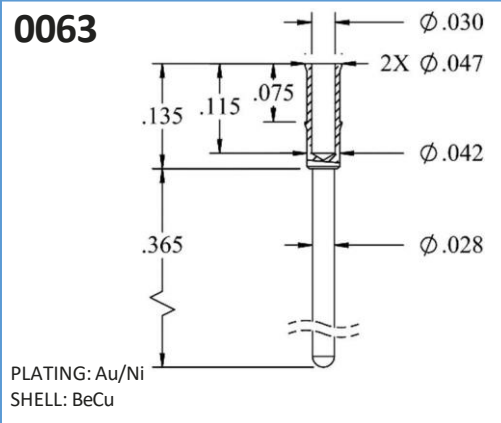
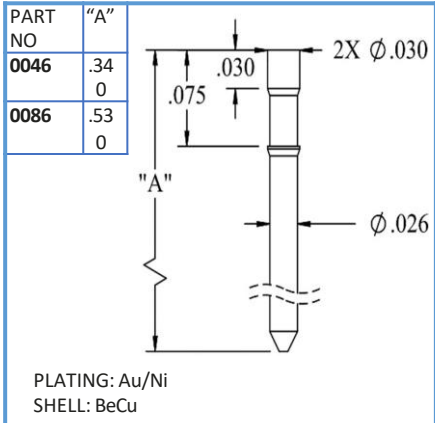

**NOTES: UNLESS OTHERWISE SPECIFIED**

SHELL / BODIES MATERIAL \ FINISH

BRASS ALLOY C36000 per ASTM-B16, Half Hard plated Gold per MIL-G-45204 Type 2, Grade C, 10µ In. Min. over Nickel, 100µ In. Min. per QQ-N-290 Class 4. Or Tin per MIL-T-10727 Type I, 200µ In. Min. over Nickel 100µ In. Min.

DIMENSIONS ARE IN INCHES

DIMENSIONAL TOLERANCES:  
LENGTHS    DIAMETERS    ANGLES  
±.005        ±.002        ±2°

DRAWINGS NOT TO SCALE

**0217**

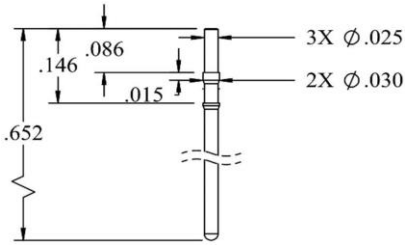

MATERIAL: PHOSPHOR BRONZE  
PLATING: MATTE TIN 150-350µIN OVER  
50µIN Ni. SHELL: BeCu

**0234**

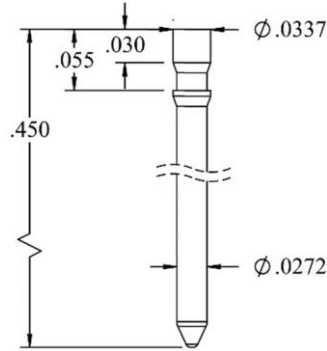

PLATING: Au/Ni  
SHELL: BeCu

**0254**

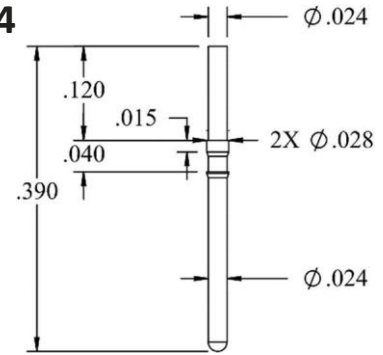

PLATING: Au/Ni  
SHELL: BeCu

**0262**

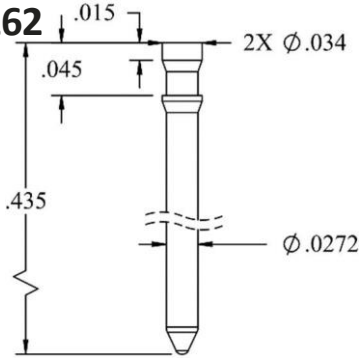

**0270**

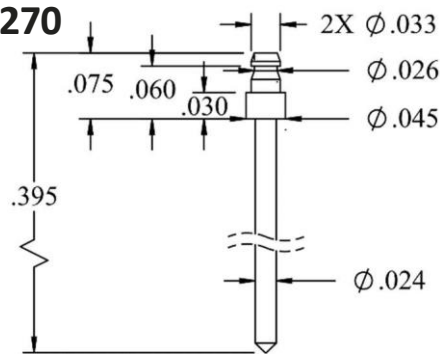

PLATING: Au/Ni  
SHELL: BeCu

**0280**

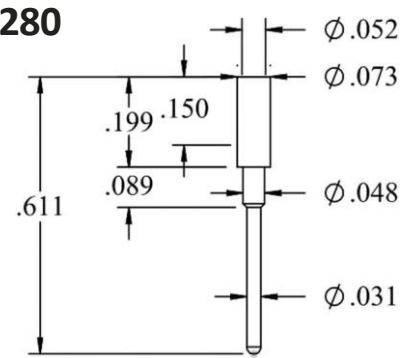

PLATING: Au/Ni  
SHELL: BeCu

**0282**

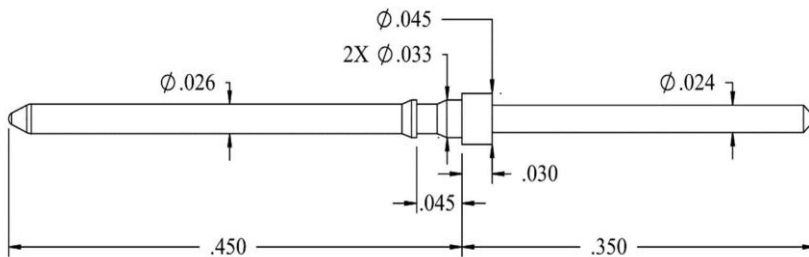

PLATING: Au/Ni  
SHELL: BeCu

**0316**

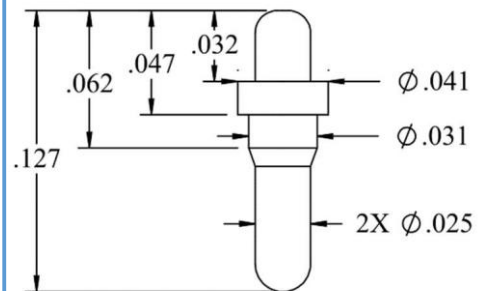

PLATING: Au/Ni  
SHELL: BeCu

**NOTES: UNLESS OTHERWISE SPECIFIED**

SHELL / BODIES

MATERIAL \ FINISH

BRASS ALLOY C36000 per ASTM-B16, Half Hard plated Gold per MIL-G-45204 Type 2, Grade C, 10µ In. Min. over Nickel, 100µ In. Min. per QQ-N-290 Class 4. Or Tin per MIL-T-10727 Type I, 200µ In. Min. over Nickel 100µ In. Min.

DIMENSIONS ARE IN INCHES

DIMENSIONAL TOLERANCES:  
LENGTHS ±.005    DIAMETERS ±.002    ANGLES ±2°

DRAWINGS NOT TO SCALE

**0348**

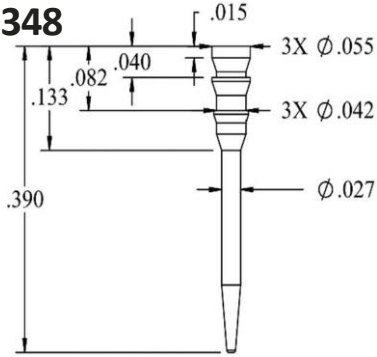

PLATING: Au/Ni  
SHELL: BeCu

**0354**

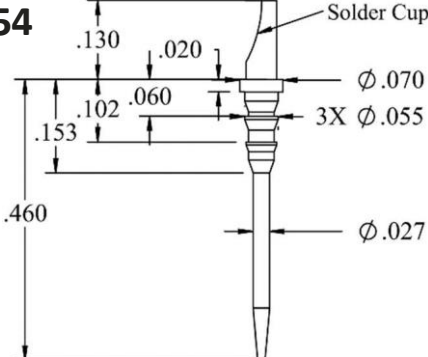

PLATING: Au/Ni  
SHELL: BeCu

PART NO	FINISH
0368	150-350µSn, 50µNi
0414	Au/Ni

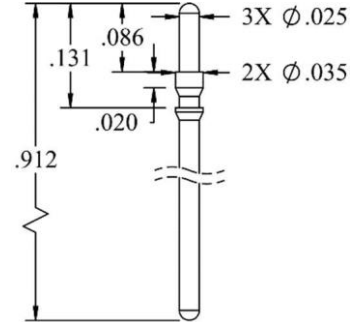

**037**

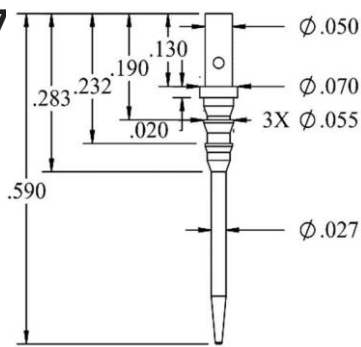

PLATING: Au/Ni  
SHELL: BeCu

**0384**

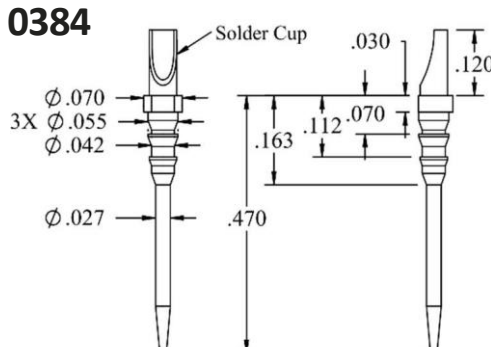

PLATING: Au/Ni  
SHELL: BeCu

**0388**

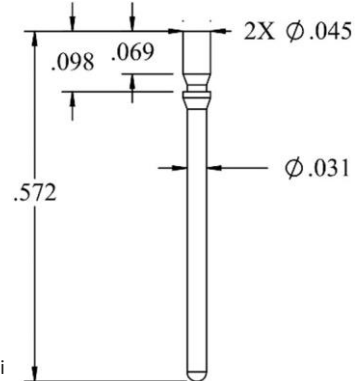

PLATING: Au/Ni  
SHELL: BeCu

**0398**

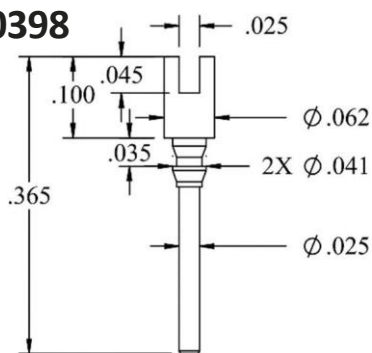

PLATING: 50µIn Au/100-200µIn Ni/10-50µIn Cu  
SHELL: BeCu

**0402**

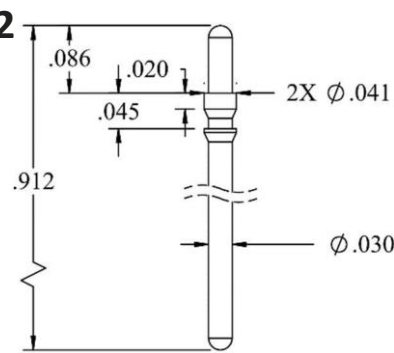

PLATING: Au/Ni  
SHELL: BeCu

**0403**

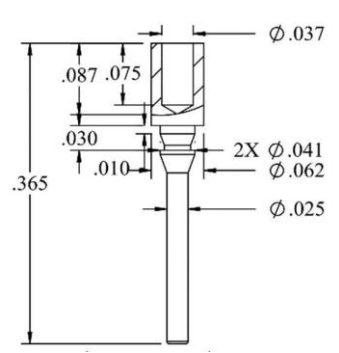

PLATING: 50µIn Au/100-200µIn Ni/10-50µIn Cu  
SHELL: BeCu

**NOTES: UNLESS OTHERWISE SPECIFIED**

SHELL / BODIES

MATERIAL \ FINISH

BRASS ALLOY C36000 per ASTM-B16, Half Hard plated Gold per MIL-G-45204 Type 2, Grade C, 10µ In. Min. over Nickel, 100µ In. Min. per QQ-N-290 Class 4. Or Tin per MIL-T-10727 Type I, 200µ In. Min. over Nickel 100µ In. Min.

DIMENSIONS ARE IN INCHES

DIMENSIONAL TOLERANCES:

DRAWINGS NOT TO SCALE

LENGTHS    DIAMETERS    ANGLES  
±.005           ±.002           ±2°

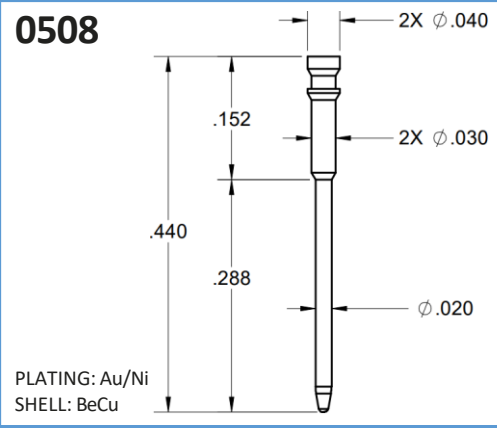
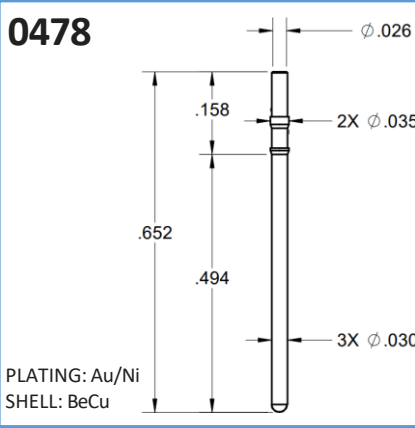
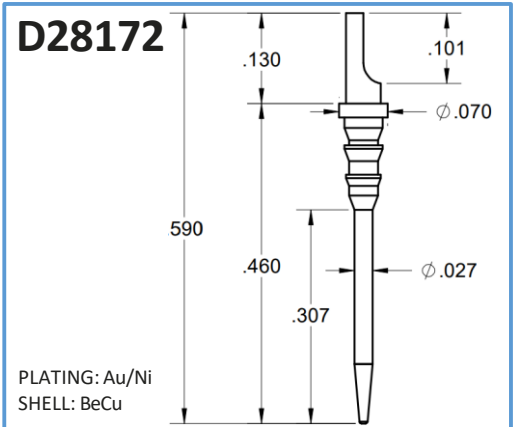
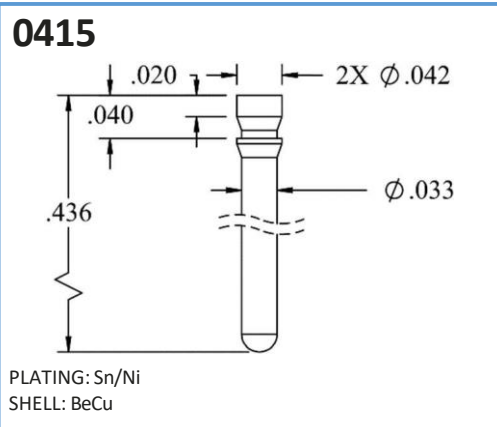
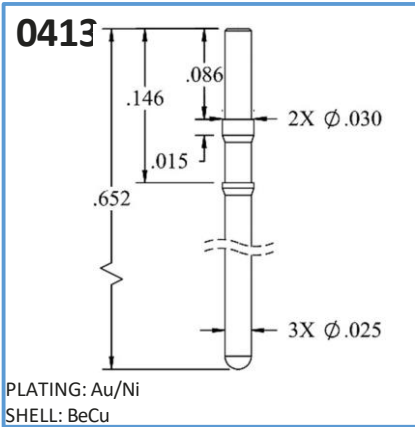

**NOTES: UNLESS OTHERWISE SPECIFIED**

SHELL / BODIES  
MATERIAL \ FINISH  
BRASS ALLOY C36000 per ASTM-B16, Half Hard plated Gold per MIL-G-45204 Type 2, Grade C, 10µ In. Min. over Nickel, 100µ In. Min. per QQ-N-290 Class 4. Or Tin per MIL-T-10727 Type I, 200µ In. Min. over Nickel 100µ In. Min.

DIMENSIONS ARE IN INCHES

DIMENSIONAL TOLERANCES:  
LENGTHS    DIAMETERS    ANGLES  
±.005        ±.002        ±2°

DRAWINGS NOT TO SCALE

### 0204

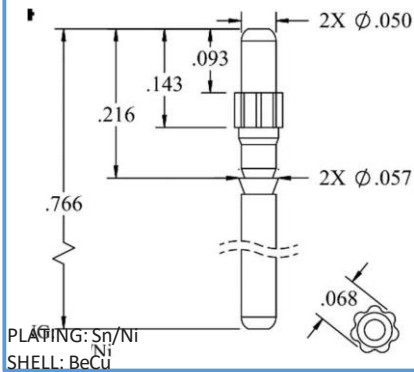

### 0206

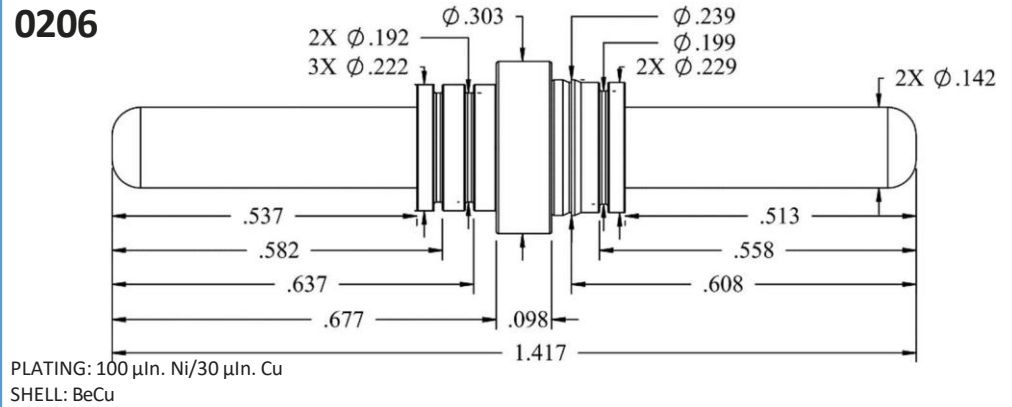

### 0207

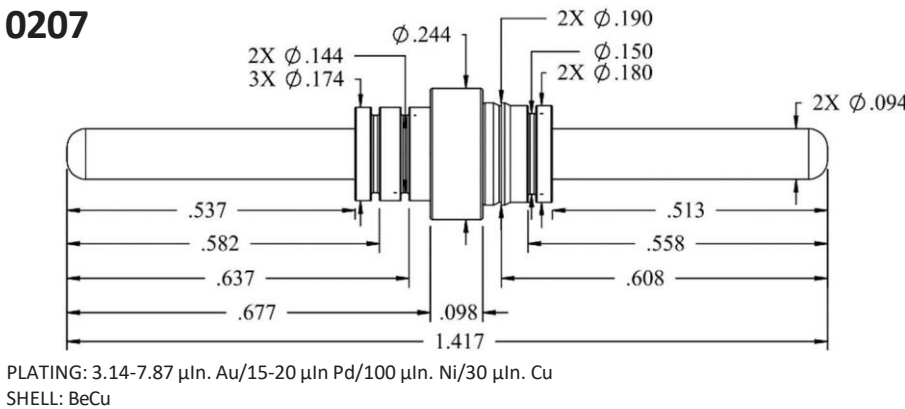

### 0209

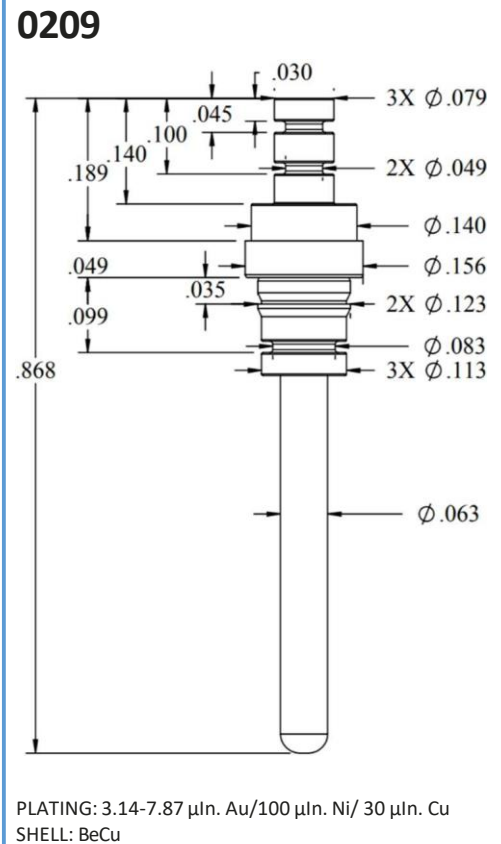

### 0208

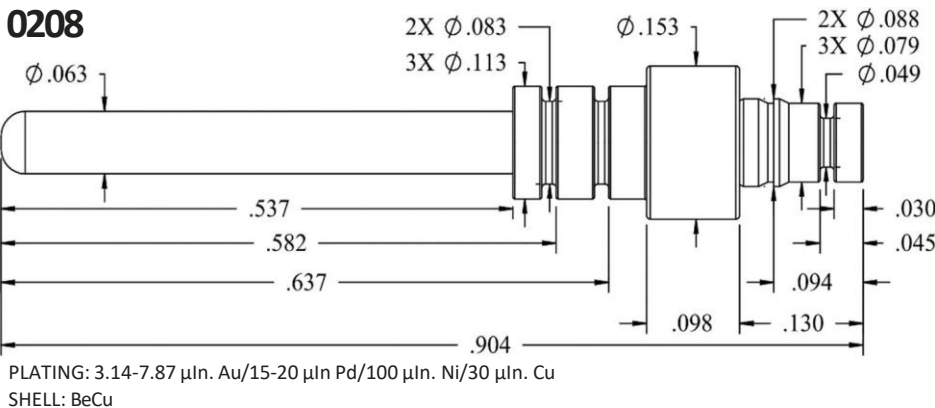

#### NOTES: UNLESS OTHERWISE SPECIFIED

##### SHELL / BODIES

##### MATERIAL \ FINISH

BRASS ALLOY C36000 per ASTM-B16, Half Hard plated Gold per MIL-G-45204 Type 2, Grade C, 10 $\mu$  In. Min. over Nickel, 100 $\mu$  In. Min. per QQ-N-290 Class 4. Or Tin per MIL-T-10727 Type I, 200 $\mu$  In. Min. over Nickel 100 $\mu$  In. Min.

DIMENSIONS ARE IN INCHES

DIMENSIONAL TOLERANCES:  
LENGTHS  $\pm .005$   
DIAMETERS  $\pm .002$   
ANGLES  $\pm 2^\circ$

DRAWINGS NOT TO SCALE



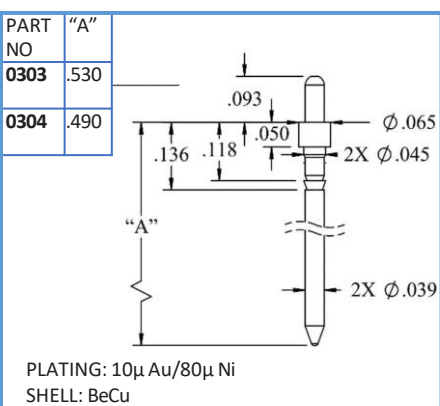
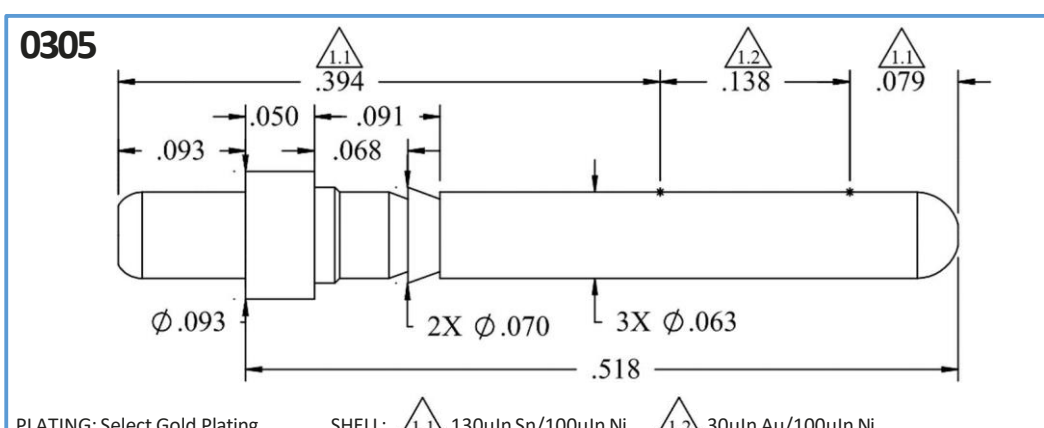
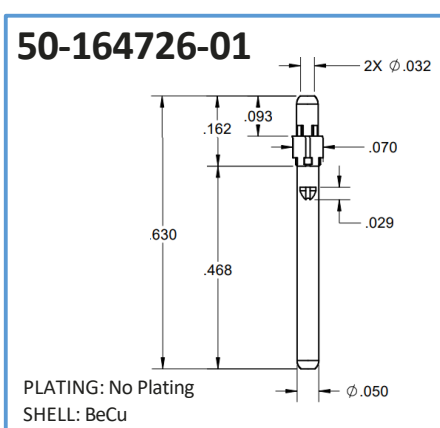
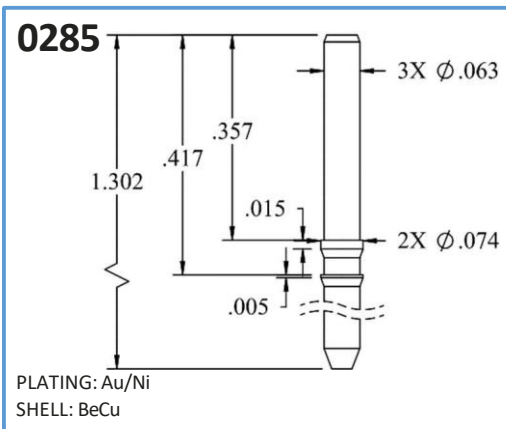
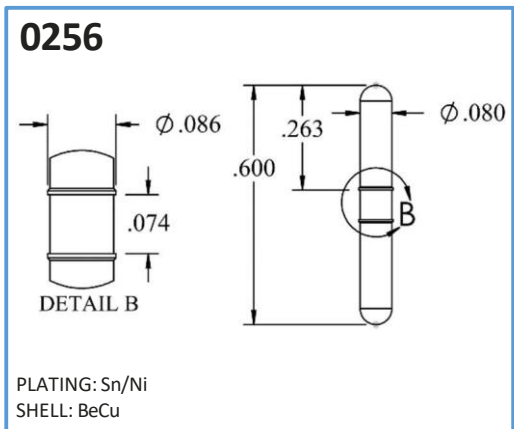
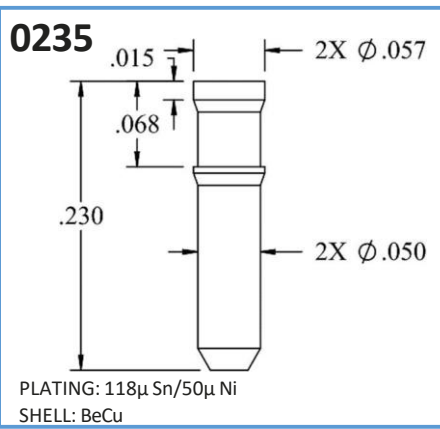
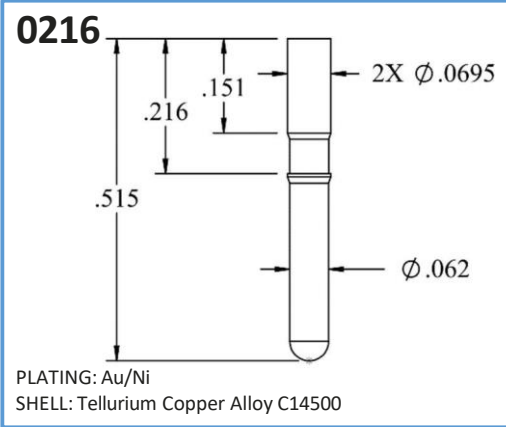
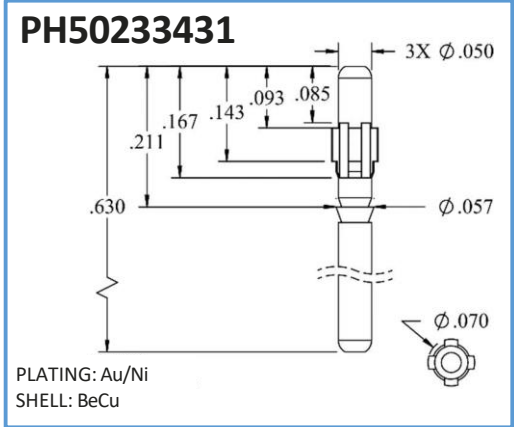
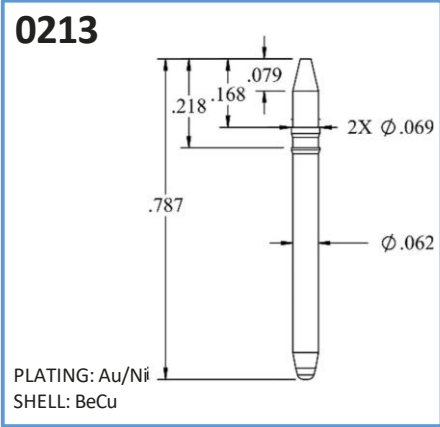

**NOTES: UNLESS OTHERWISE SPECIFIED**

**SHELL / BODIES**

**MATERIAL \ FINISH**

BRASS ALLOY C36000 per ASTM-B16, Half Hard plated Gold per MIL-G-45204 Type 2, Grade C, 10 $\mu$  In. Min. over Nickel, 100 $\mu$  In. Min. per QQ-N-290 Class 4. Or Tin per MIL-T-10727 Type I, 200 $\mu$  In. Min. over Nickel 100 $\mu$  In. Min.

DIMENSIONS ARE IN INCHES

DIMENSIONAL TOLERANCES:  
LENGTHS  $\pm .005$   
DIAMETERS  $\pm .002$   
ANGLES  $\pm 2^\circ$

DRAWINGS NOT TO SCALE

**0308**

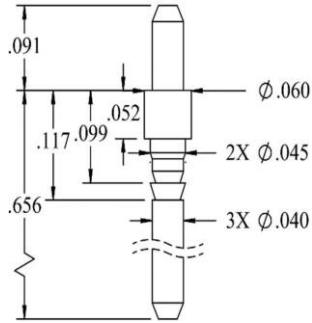

PLATING: 118 $\mu$  Sn/50 $\mu$  Ni SHELL: BeCu

**0310**

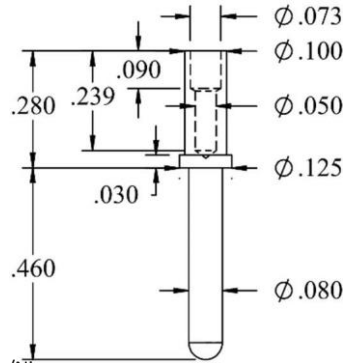

PLATING: Sn/Ni  
SHELL: BeCu

**0343**

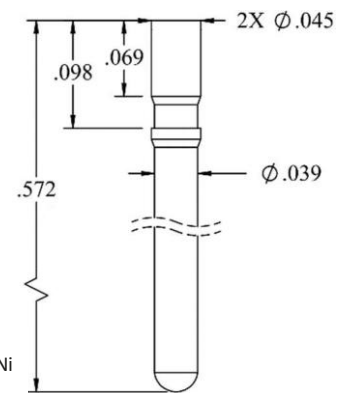

PLATING: Au/Ni  
SHELL: BeCu

**0351**

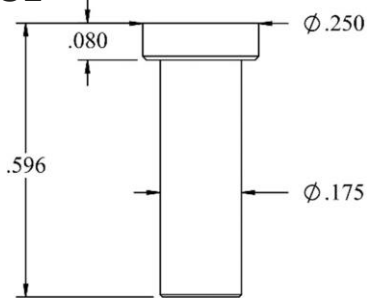

PLATING: None  
MATERIAL: UNS S42000 Stainless Steel

**0358**

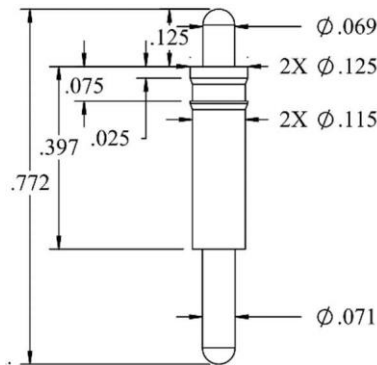

PLATING: Sn/Ni  
SHELL: BeCu

**0369**

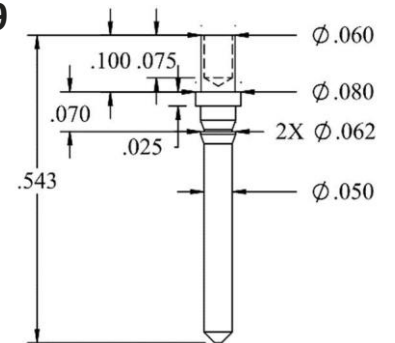

PLATING: 200 $\mu$  Ni  
SHELL: BeCu

**0397**

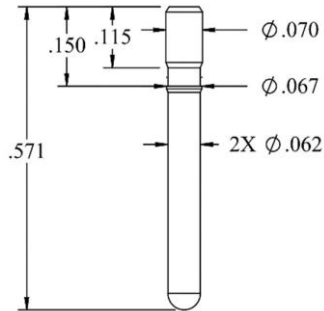

PLATING: Au/Ni  
SHELL: Tellurium Copper Alloy C14500

**0407**

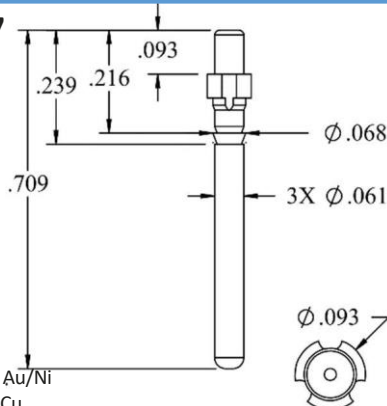

PLATING: Au/Ni  
SHELL: BeCu

**0408**

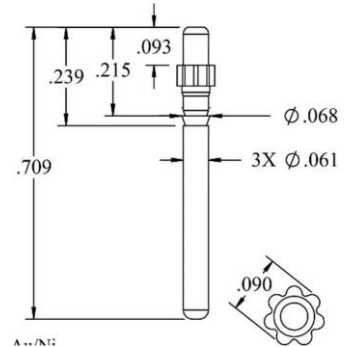

PLATING: Au/Ni  
SHELL: I

**NOTES: UNLESS OTHERWISE SPECIFIED**

SHELL / BODIES

MATERIAL \ FINISH

BRASS ALLOY C36000 per ASTM-B16, Half Hard plated Gold per MIL-G-45204 Type 2, Grade C, 10 $\mu$  In. Min. over Nickel, 100 $\mu$  In. Min, per QQ-N-290 Class

4. Or Tin per MIL-T-10727 Type I, 200 $\mu$  In. Min. over Nickel 100 $\mu$  In. Min.

DIMENSIONS ARE IN INCHES

DIMENSIONAL TOLERANCES:

LENGTHS    DIAMETERS    ANGLES  
 $\pm .005$              $\pm .002$              $\pm 2^\circ$

DRAWINGS NOT TO SCALE

### 0410

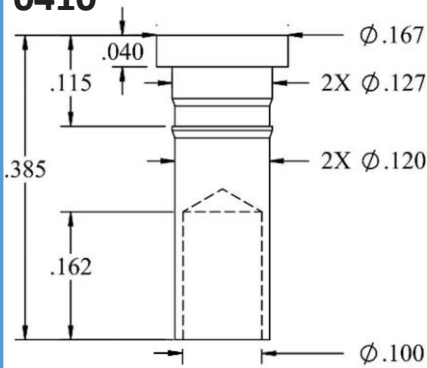

PLATING: Sn/Ni SHELL: BeCu

### 0428

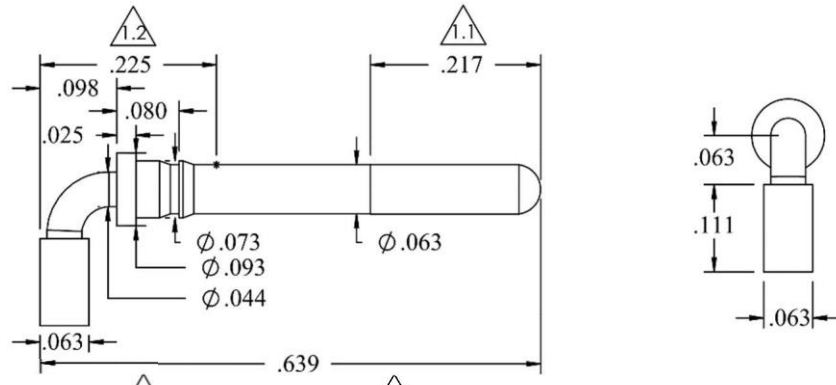

SHELL: BeCu PLATING:  $\Delta 1.1$  130 $\mu$ In Sn/100 $\mu$ In Ni  $\Delta 1.2$  30 $\mu$ In Au/100 $\mu$ In Ni

### 0432

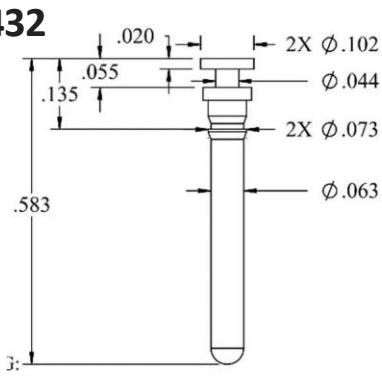

PLATING: Au/Ni SHELL: BeCu

### 0433

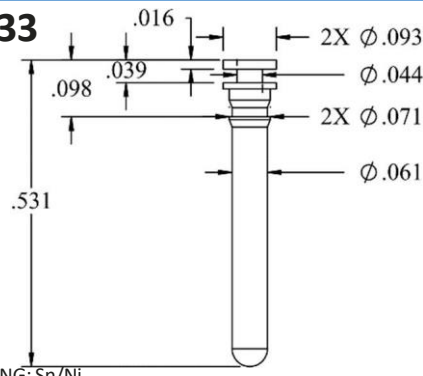

PLATING: Sn/Ni SHELL: BeCu

### 0435

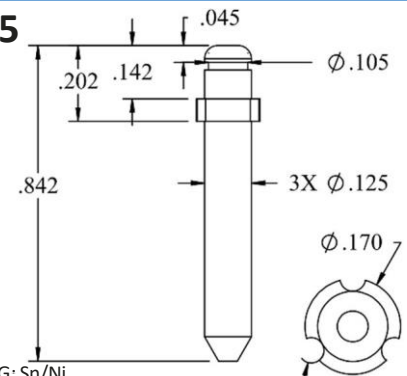

PLATING: Sn/Ni SHELL: BeCu

### PH50188660

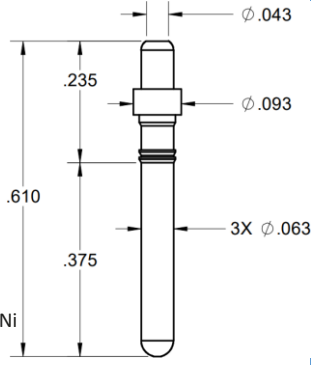

PLATING: Au/Ni SHELL: BeCu

#### NOTES: UNLESS OTHERWISE SPECIFIED

##### SHELL / BODIES

##### MATERIAL \ FINISH

BRASS ALLOY C36000 per ASTM-B16, Half Hard plated Gold per MIL-G-45204 Type 2, Grade C, 10 $\mu$  In. Min. over Nickel, 100 $\mu$  In. Min. per QQ-N-290 Class 4. Or Tin per MIL-T-10727 Type I, 200 $\mu$  In. Min. over Nickel 100 $\mu$  In. Min.

DIMENSIONS ARE IN INCHES

DIMENSIONAL TOLERANCES:  
LENGTHS  $\pm .005$  DIAMETERS  $\pm .002$  ANGLES  $\pm 2^\circ$

DRAWINGS NOT TO SCALE

**0202**

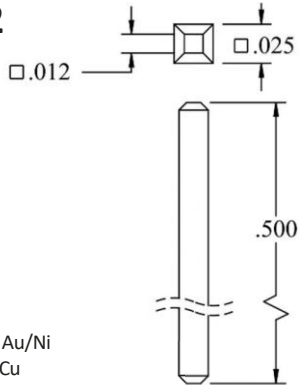

PLATING: Au/Ni  
SHELL: BeCu  
MATERIAL: CDA 510 PHOSPHOR BRONZE

**0031**

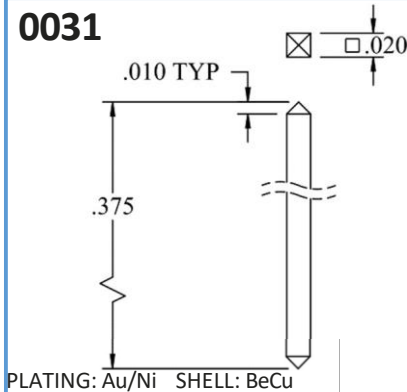

PLATING: Au/Ni SHELL: BeCu

**NOTES: UNLESS OTHERWISE SPECIFIED**

SHELL / BODIES

MATERIAL \ FINISH

BRASS ALLOY C36000 per ASTM-B16, Half Hard plated Gold per MIL-G-45204 Type 2, Grade C, 10µ In. Min. over Nickel, 100µ In. Min. per QQ-N-290 Class

4. Or Tin per MIL-T-10727 Type I, 200µ In. Min. over Nickel 100µ In. Min.

DIMENSIONS ARE IN INCHES

DIMENSIONAL TOLERANCES:  
LENGTHS    DIAMETERS    ANGLES  
±.005           ±.002           ±2°

DRAWINGS NOT TO SCALE

**0193**

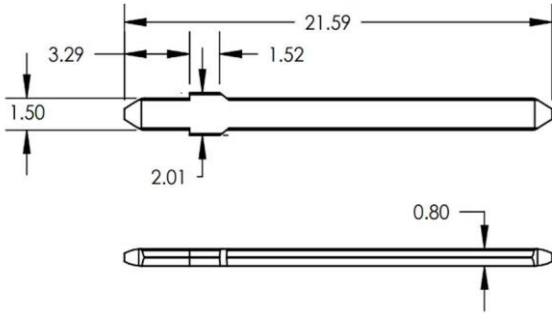

PLATING: Sn/Ni

**0194**

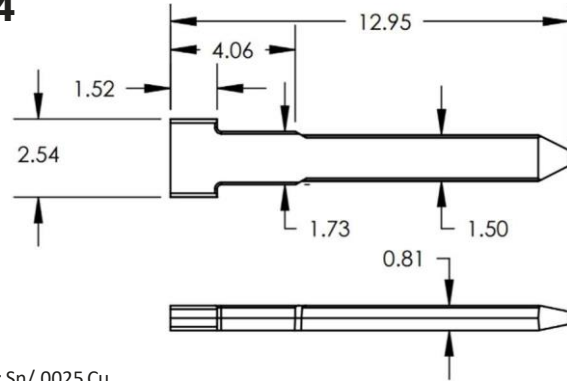

PLATING: Sn/.0025 Cu

**0196**

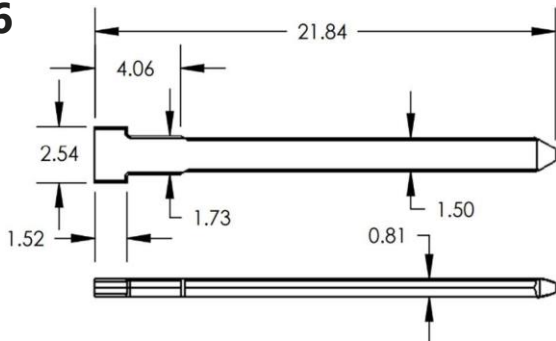

PLATING: Sn/.0025 Cu

**0198**

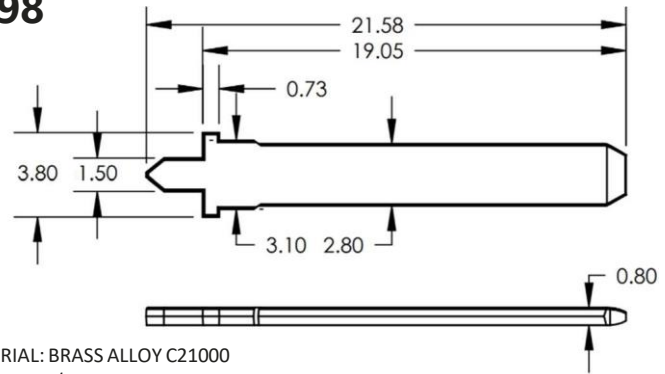

MATERIAL: BRASS ALLOY C21000  
PLATING: Sn/Ni

PART NO.	PLATING
0229	Sn/Ni
0431	Au/Ni

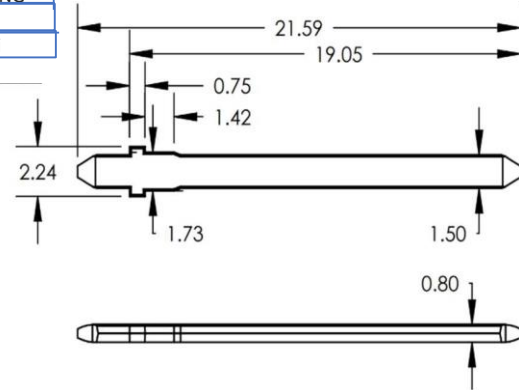

**0230**

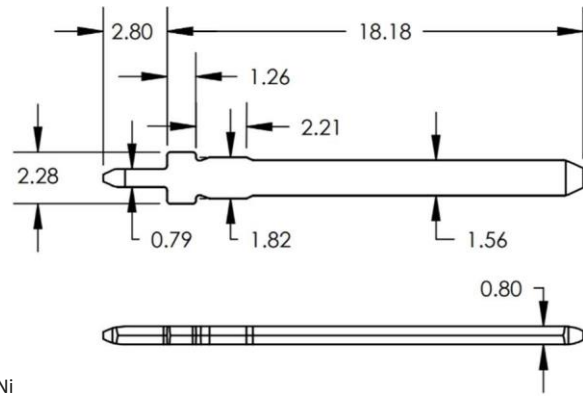

PLATING: Sn/Ni

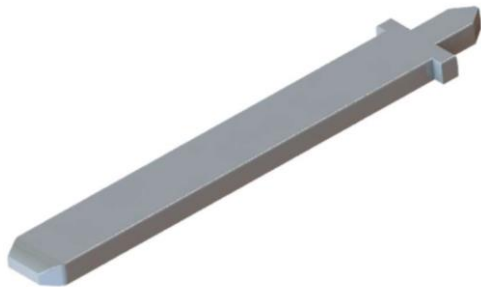

**NOTES: UNLESS OTHERWISE SPECIFIED**

**SHELL / BODIES**

**MATERIAL \ FINISH**

BRASS ALLOY C26000 per ASTM-B36, 3/4 hard plated 0.0035 Electroplated Matte Tin over 0.0025 Nickel or plated 0.000254 Gold over 0.0025 Ni

Pins meet solderability requirements of IPC/EIA J-STD-002, Test A, Category 1

DIMENSIONS ARE IN  
MILIMETERS

DIAMETERS  
±.05

DIMENSIONAL TOLERANCES:

ANGLES  
±2°

DRAWINGS NOT TO SCALE

LENGTHS  
±.013

## 0231

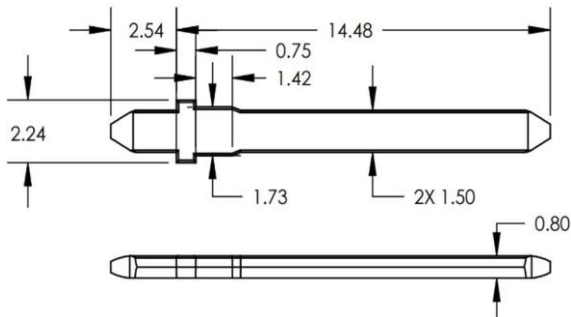

PLATING: Sn/Ni

## 0232

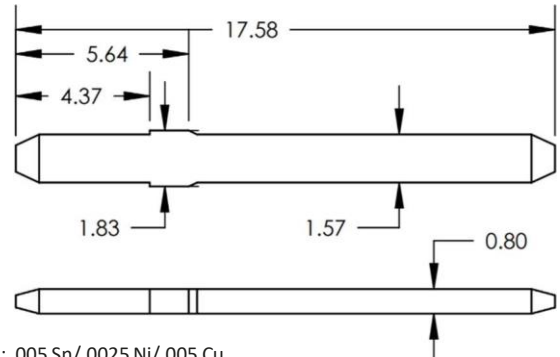

PLATING: .005 Sn/.0025 Ni/.005 Cu

## 0265

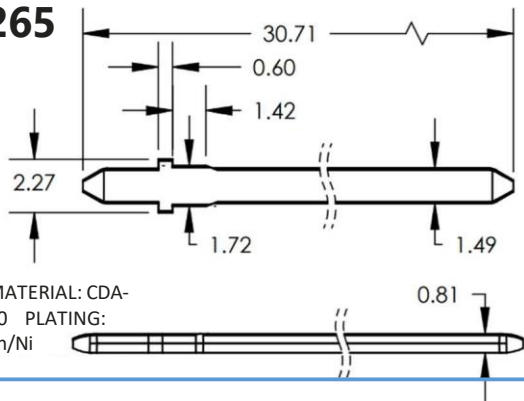

MATERIAL: CDA-20  
PLATING: Sn/Ni

## 0295

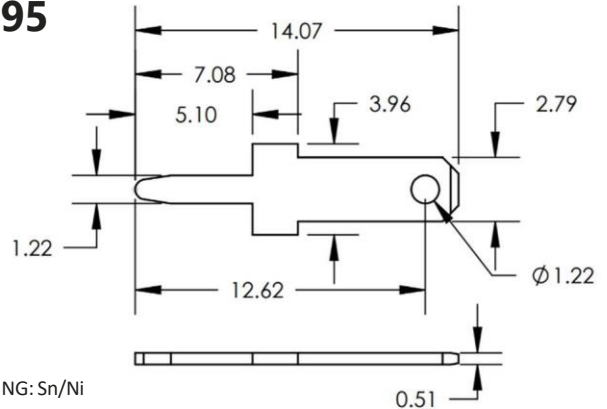

PLATING: Sn/Ni

PART NO	"A"
0296	3.55
0297	2.70

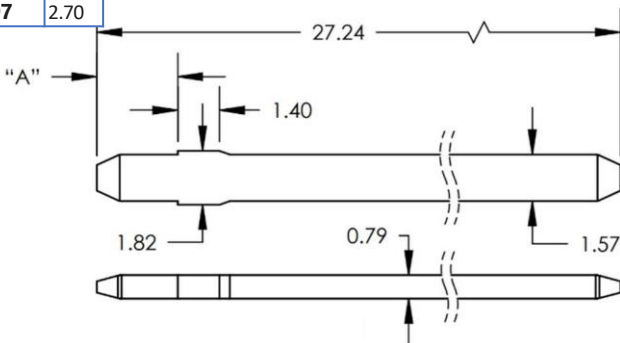

PLATING: 0.000762 Au/0.00127 Ni

PART NO	FINISH
0298	Sn/Ni
0299	.0005 Au/.0013 Ni

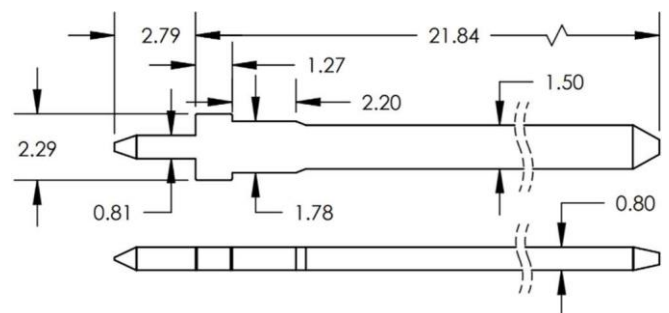

### NOTES: UNLESS OTHERWISE SPECIFIED

SHELL / BODIES

MATERIAL \ FINISH

BRASS ALLOY C26000 per ASTM-B36, 3/4 hard plated 0.0035 Electroplated Matte Tine over 0.0025 Nickel or plated 0.000254 Gold over 0.0025 Ni

Pins meet solderability requirements of IPC/EIA J-STD-002, Test A, Category 1

DIMENSIONS ARE IN  
MILLIMETERS  
DIAMETERS  
±.05

DIMENSIONAL TOLERANCES:  
ANGLES  
±2°

DRAWINGS NOT TO SCALE  
LENGTHS  
±.013

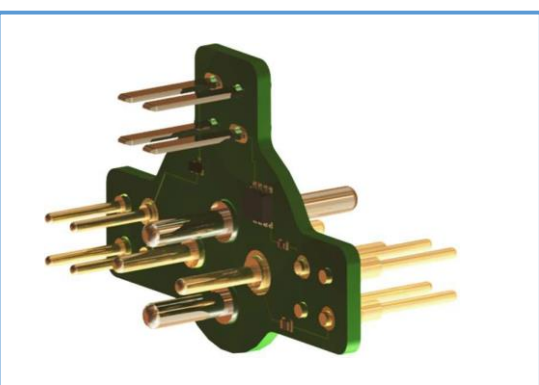
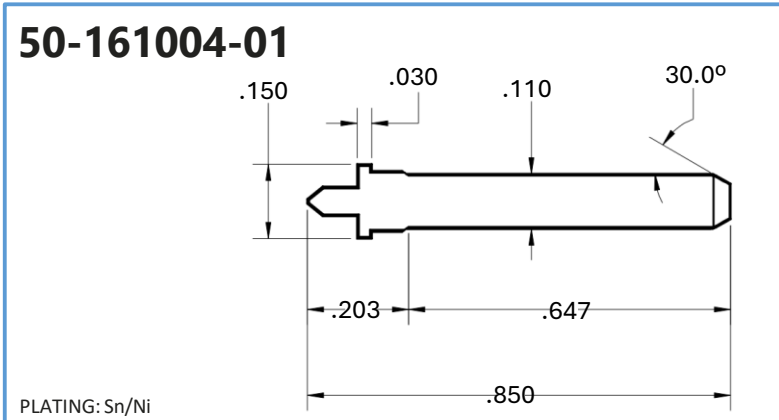
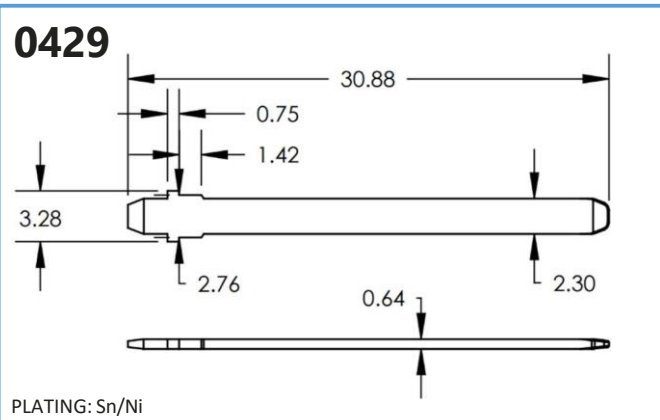
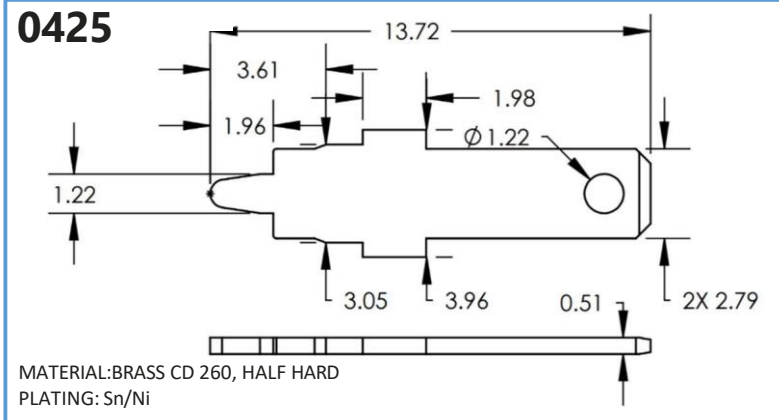
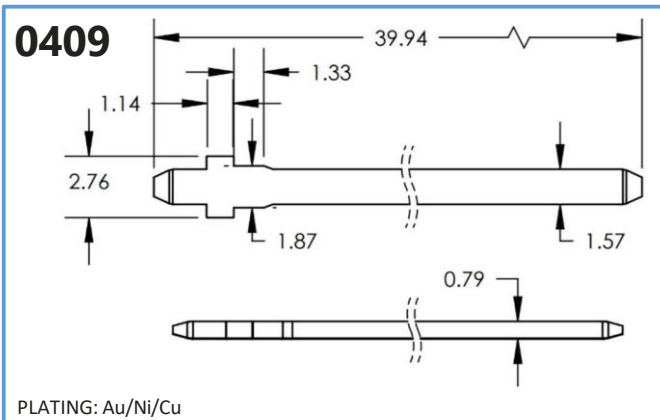
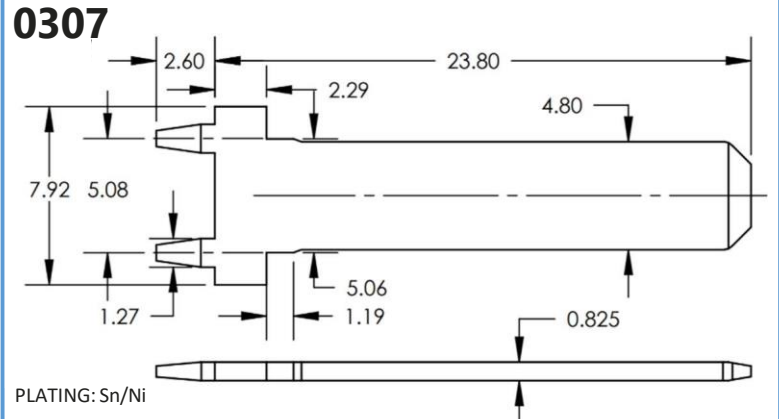
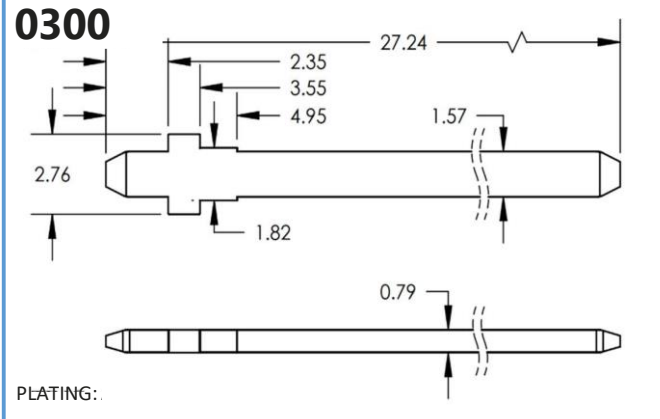

**NOTES: UNLESS OTHERWISE SPECIFIED**

SHELL / BODIES  
MATERIAL \ FINISH  
BRASS ALLOY C26000 per ASTM-B36, 3/4 hard plated 0.0035 Electroplated Matte Tine over 0.0025 Nickel or plated 0.000254 Gold over 0.0025 Ni  
Pins meet solderability requirements of IPC/EIA J-STD-002, Test A, Category 1

DIMENSIONS ARE IN MILIMETERS	DIMENSIONAL TOLERANCES:	<u>DRAWINGS NOT TO SCALE</u>
DIAMETERS ±.05	ANGLES ±2°	LENGTHS ±.013

PART NO	"A"	FINISH
0266	21.84	Au/Ni
0277	21.84	Sn/Ni
0279	16.55	Sn/Ni
0278	12.95	Sn/Ni
0434	12.95	Au/Ni
0430	18.01	Sn/Ni/Cu

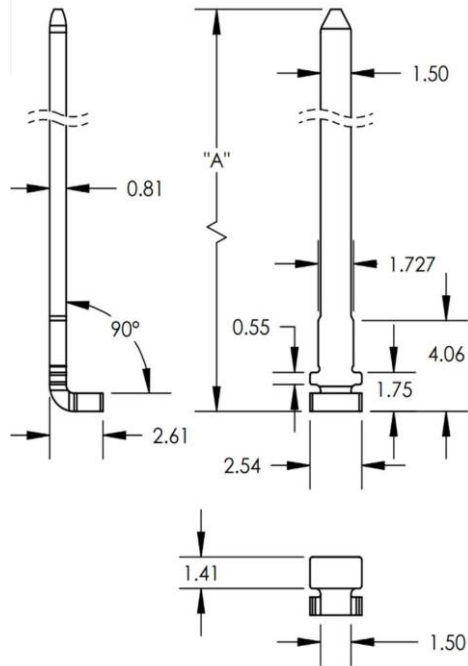

## 0426

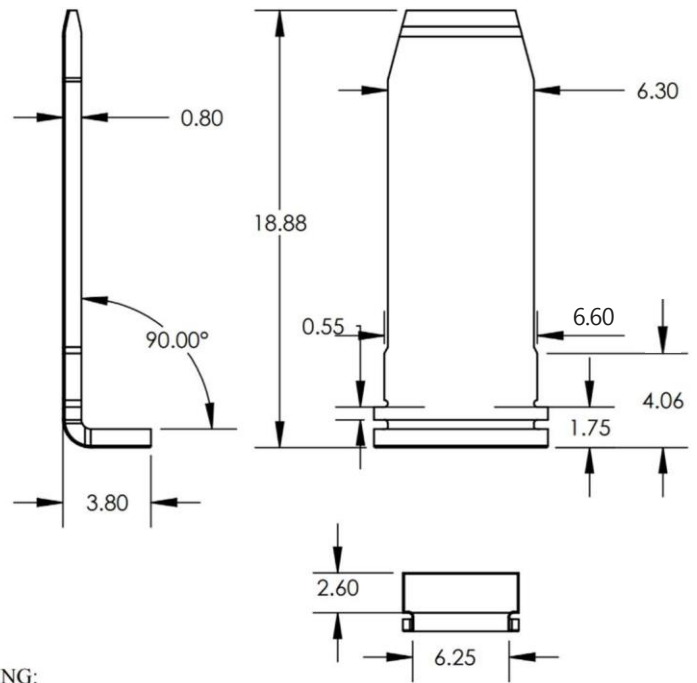

PLATING:

PLATING: Sn/Ni/Cu

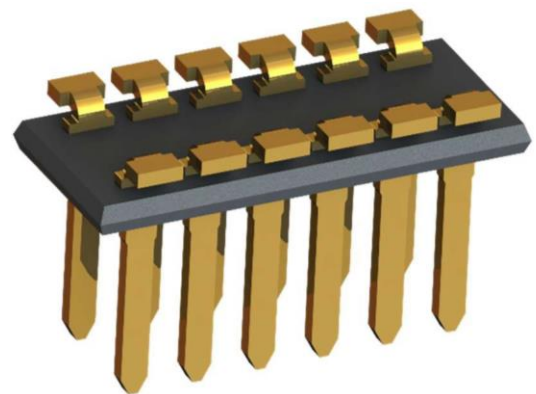

### NOTES: UNLESS OTHERWISE SPECIFIED

SHELL/

BODIES

MATERIAL \

FINISH

BRASS ALLOY C26000 per ASTM-B36, ¾ hard plated 0.0035 Electroplated Matte Tine over 0.0025 Nickel or plated 0.000254 Gold over 0.0025 Ni Pins meet solderability requirements of IPC/EIA J-STD-002, Test A, Category 1

DIMENSIONS ARE IN  
MILIMETERS

LENGTHS  
±.013

DIMENSIONAL  
TOLERANCES:

DIAMETERS  
±.05

DRAWINGS NOT TO  
SCALE

ANGLES  
±2°

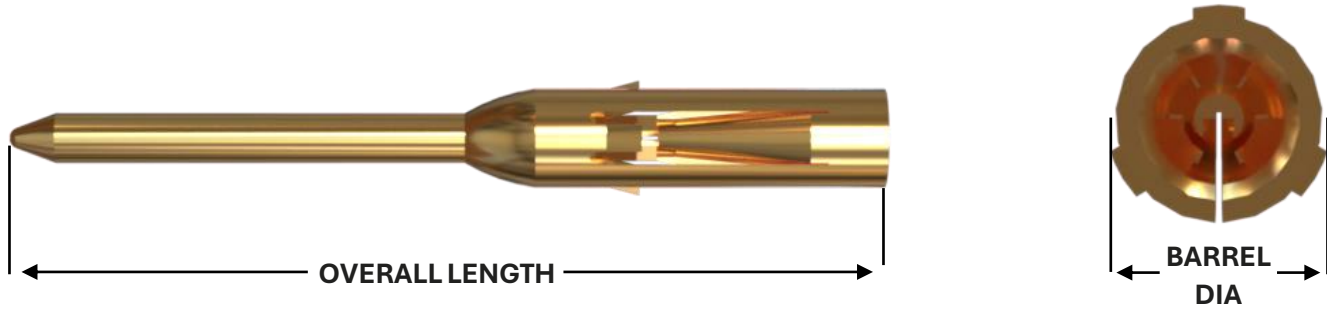

PART NUMBER	FINGER CONTACT	BARREL DIAMETER (in)	OVERALL LENGTH (in)	TEST PIN	MAXIMUM INSERTION FORCE	MINIMUM WITHDRAWAL FORCE
838	4	0.053	0.315	.017 DIA	165 GM	45 GM
839	3	0.034	0.300	.018 DIA	25 Gm	10 GM
840	3	0.034	0.262	.018 DIA	25 GM	10 GM
23	3	0.034	0.285	.018 DIA	25 GM	10 GM
57	3	0.028	0.300	.012 SQ .014 DIA	42 GM	10 GM
37	3	0.028	0.220	.012 SQ .014 DIA	42 GM	10 GM
14	3	0.028	0.180	.012 SQ .014 DIA	42 GM	10 GM
11	3	0.028	0.250	.012 SQ .014 DIA	42 GM	10 GM

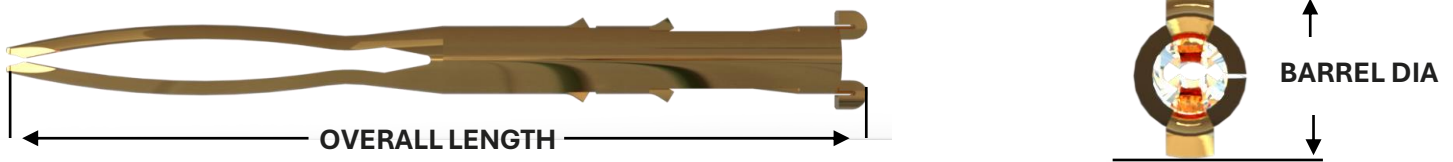

PART NUMBER	FINGER CONTACT	BARREL DIAMETER (in)	OVERALL LENGTH (in)	TEST PIN	MAXIMUM INSERTION FORCE	MINIMUM WITHDRAWAL FORCE
0437	2	0.035	.293	.012 DIA	42 GM	10 GM



### NOTES: UNLESS OTHERWISE SPECIFIED

#### CONTACTS MATERIAL \ FINISH

Beryllium Copper, Alloy C17200 per ASTM-B194, heat treated, plated Gold per MIL-G-45204 Type 2, Grade C, Class 0, 30µIn. Min. or Class 00, 10µIn. Min., over Nickel per QQ-N-290 Class 4, 50µIn. Min.  
Or; Tin per MIL-T-10727 Type I, 200µIn. Min over Nickel, 50µIn.

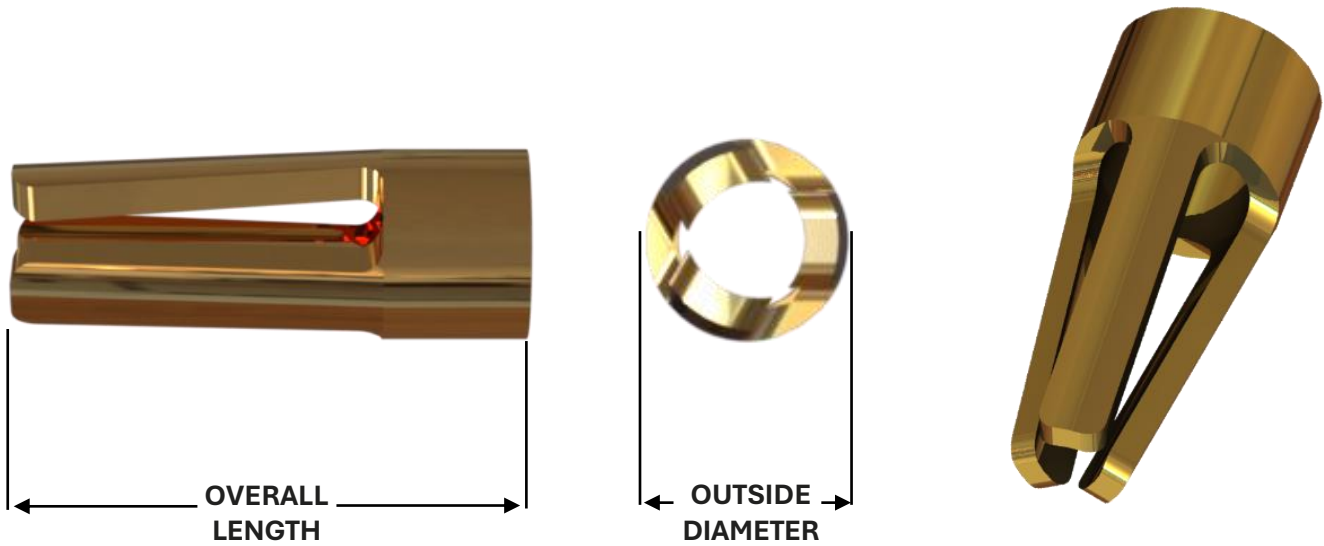

PART NUMBER	OUTSIDE DIAMETER (in)	OVERALL LENGTH (in)	OPERATING RANGE PIN DIA. (in)	TEST PIN DIAMETER (in)	MAXIMUM INSERTION FORCE	MINIMUM REMOVAL FORCE
94	0.031	0.075	.015-.020	0.017	80 GM	15 GM
823	0.031	0.075	.015-.021	0.018	90 GM	14 GM
203	0.032	0.05	.015-.018	0.017	400 GM	100 GM
132	0.031	0.075	.015-.020	0.017	42 GM	14 GM
286	0.031	0.075	.015-.021	0.018	30 GM	10 GM
462	0.0235	0.065	.007-.013	0.011	30 GM	9 GM
311	0.0196	0.053	.006-.011	0.008	30 GM	10 GM



**NOTES: UNLESS OTHERWISE SPECIFIED**

CONTACTS

MATERIAL \ FINISH

Beryllium Copper, Alloy C17200 per ASTM-B194, heat treated, plated Gold per MIL-G-45204 Type 2, Grade C, Class 0, 30µIn. Min. or Class 00, 10µIn. Min., over Nickel per QQ-N-290 Class 4, 50µIn. Min.  
Or; Tin per MIL-T-10727 Type I, 200µIn. Min over Nickel, 50µIn.

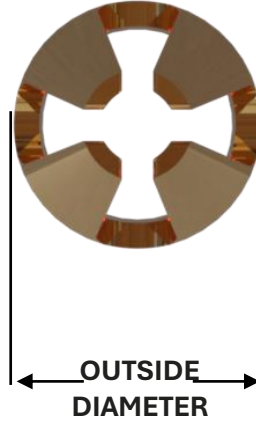
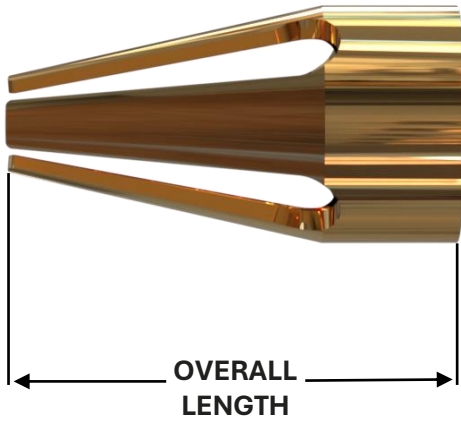

PART NUMBER	OUTSIDE DIAMETER (in)	OVERALL LENGTH (in)	OPERATING RANGE PIN DIA. (in)	TEST PIN DIAMETER (in)	MAXIMUM INSERTION FORCE	MINIMUM WITHDRAWAL FORCE
42	0.044	0.065	.015-.022	0.018	135 GM	25 GM
822	0.044	0.065	.015-.022	0.018	260 Gm	55 GM
824	0.044	0.065	.015-.022	0.018	520 GM	120 GM
825	0.044	0.083	.015-.022	0.018	45 GM	15 GM
137	0.044	0.083	.015-.025	0.017	270 GM	90 GM
826	0.044	0.083	.015-.025	0.018	675 Gm	200 GM
827	0.053	0.117	.022-.032	I - 0.026 W - 0.024	385 GM	50 GM
828	0.069	0.15	.036-.050	0.040 / 0.030	325 GM / 55 GM	60 GM / 15 GM
291	0.08	0.15	.040-.059	I - 0.05 W 0.04	375 GM	35 GM
829	0.064	0.095	.032-.045	0.04	5 LB	200 GM
830	0.0635	0.12	.032-.046	0.041 / 0.039	350 GM	55 GM
831	0.064	0.12	.032-.045	I - 0.04 W - 0.035	2.25 LB	110 GM
365	0.088	0.124	.048-.064	I - 0.06 W - 0.05	440 GM	60 GM
292	0.108	0.148	.065-.082	I - 0.074 W - 0.072	3 LB	230 GM

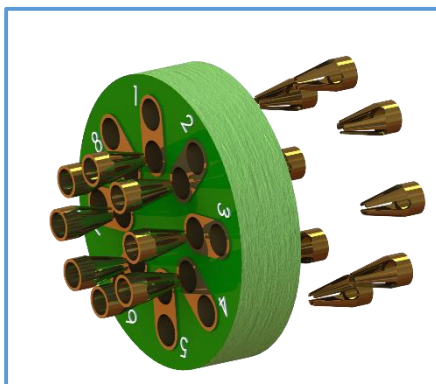

**NOTES: UNLESS OTHERWISE SPECIFIED**

CONTACTS

MATERIAL \ FINISH

Beryllium Copper, Alloy C17200 per ASTM-B194, heat treated, plated Gold per MIL-G-45204 Type 2, Grade C, Class 0, 30µIn. Min. or Class 00, 10µIn. Min., over Nickel per QQ-N-290 Class 4, 50µIn. Min.

Or; Tin per MIL-T-10727 Type I, 200µIn. Min over Nickel, 50µIn.

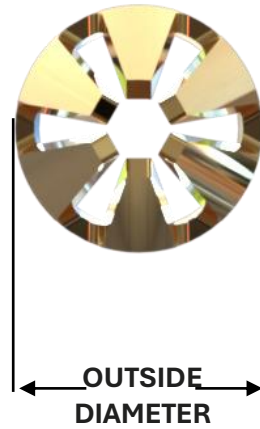
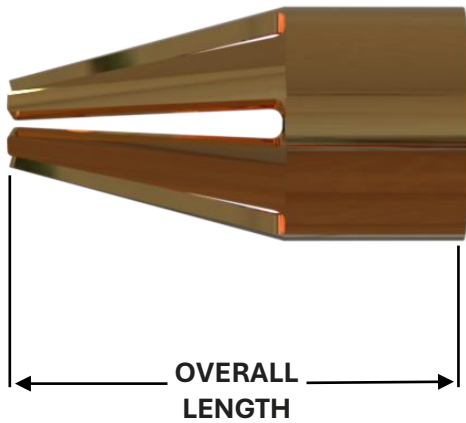

PART NUMBER	OUTSIDE DIAMETER (in)	OVERALL LENGTH (in)	OPERATING RANGE PIN DIA. (in)	TEST PIN DIAMETER (in)	MAXIMUM INSERTION FORCE	MINIMUM WITHDRAWAL FORCE
309	0.028	0.06	0.012 - 0.017	0.015	250GM	42GM
452	0.031	0.06	0.012-0.019	0.015	60GM	15GM
832	0.044	0.062	0.015-0.023	0.017	150GM	40GM
833	0.044	0.062	0.015-0.023	0.017	120GM	20GM
834	0.044	0.083	0.015-0.026	0.017	90GM	25GM
329	0.044	0.083	0.015-0.026	0.018	42GM	15GM
835	0.044	0.083	0.015-0.026	0.018	20GM	10GM
284	0.05	0.083	0.025-0.035	0.026	140GM	25GM
836	0.052	0.083	0.025-0.037	0.026	375GM	100GM
837	0.052	0.083	0.025-0.037	0.026	125GM	40GM
366	0.055	0.065	0.037-0.043	0.04	160GM	50GM
455	0.068	0.085	0.04-0.05	0.04	300GM	75GM
457	0.1235	0.12	0.084-0.102	0.093	600GM	150GM

## NOTES: UNLESS OTHERWISE SPECIFIED

### CONTACTS MATERIAL \ FINISH

Beryllium Copper, Alloy C17200 per ASTM-B194, heat treated, plated Gold per MIL-G-45204 Type 2, Grade C, Class 0, 30µIn. Min. or Class 00, 10µIn. Min., over Nickel per QQ-N-290 Class 4, 50µIn. Min. Or; Tin per MIL-T-10727 Type I, 200µIn. Min over Nickel, 50µIn.

ABS – Acrylonitrile Butadlene Sytrene	MC® 907 Natural
Acetal	Meldin®
Acetron GP	Micarta®
Acetate	Mylar®
Acrylic	Nylatron® GS
Celazole	Nylatron GM Blue
Celcon® – Acetak Co-Polymer	Nylatron GSM
Cellulose Acetate	Nylon 101
Cirlex®	Nylon 6/6
Copper Clad Laminates	Orkot®
CPVC – High Temperature PVC	Phenolic
Delrin®	Line Phenolic
Delrin® Acetal	Paper Phenolic
Delrin® AF Blend	PC 1000 Polysulfone
Duratron® 150	PET
Duratron® XP	Plexiglas®
Ertalyte® PET-P	Polycarbonate
Ertalyte® TX	Polyimide
FEP – Fluorinated Ethylene Propylene	Polyphthalamide
Fluoroglas®	Polypropylene
Fluorosint® 207 PTFE	Polyshell – 01 (Virgin PTFE)
Fluorosint® 500 PTFE	Polyshell – 02 (Premium PTFE Blue)
FR-4 / IPC-4101	Polyshell – 03 (Graphite Filled PTFE)
G10	Polyshell – 04 (Carbon/Graphite Filled PTFE)
G11	Polyshell – 05 (Carbon/Graphite Filled PTFE)
Haylar®	Polyshell – 06 (Glass/Moly Filled PTFE)
HDPE (High Density Polyethelyne)	Polyshell – 07 (Glass/Moly Filled PTFE)
Hydar®	Polyshell – 08 (UHMWPE)
Kapton®	Polyshell – 09 (Filled PTFE)
Kel-F® (Polychlorotrifluoroethylene)	Polyshell – 10 (Filled PTFE)
Ketron® PEEK HPV	Polyshell – 11 (Premium PTFE White FDA)
Ketron® PEEK 1000	Polyshell – 12 (Virgin PEEK)
Ketron® PEEK 30% Glass Filled	Polyshell – 13 (Glass Filled PTFE)
Ketron® PEEK CA30	Polystyrene
Ketron® PEEK HT	Polysulfone
Kydex®	Polyurethane
Kynar®	PVC (Polyvinylchloride)
LCP	Radel R
LDPE (Low Density Polyethylene)	Rexolite®
Lexan®	Rulon® LR
MC® 901 Blue	

Rulon® J	Tuffak® – Polycarbonate
Ryton® PPS 40% Glass Filled	Turcite®
Ryton® PPS Bearing Guide	Tygon®
Santoprene	UHMW – Ultra High Molecular Weight
Semitron® ESD 225	Ultem 1000
Semitron® ESD 410C	Ultem 2300
Semitron® ESD 520 HR	Vespel® SP-1
Silicone	Vespel® SP-21
Techtron® HPV	Vespel® SP -211
Techtron® PPC	Vespel® SP-22
Techtron CM PPS	Vespel® SP-3
Teflon®	Vespel® TP-2236
Teflon® Glass Filled	Vespel® TP-2875
Teflon® Graphite Filled	Vespel® TP-8311
Teflon® Bronze Filled	Vespel® CR-6100
Teflon® Molybdenum Disulfide Filled	Vespel® CR-6200
Tefzel®	Vespel® CR-6300
Torlon® 4203	Vespel® CR-6500
Torlon® 4301	Vespel® CP-8000
Torlon® 4501	Vespel® CP-8001
Torlon® 4503	Vespel® CP-8002
Torlon® 5530	Vespel® ABS-5000
Tivar®	Zelux®
	We are not limited to these materials

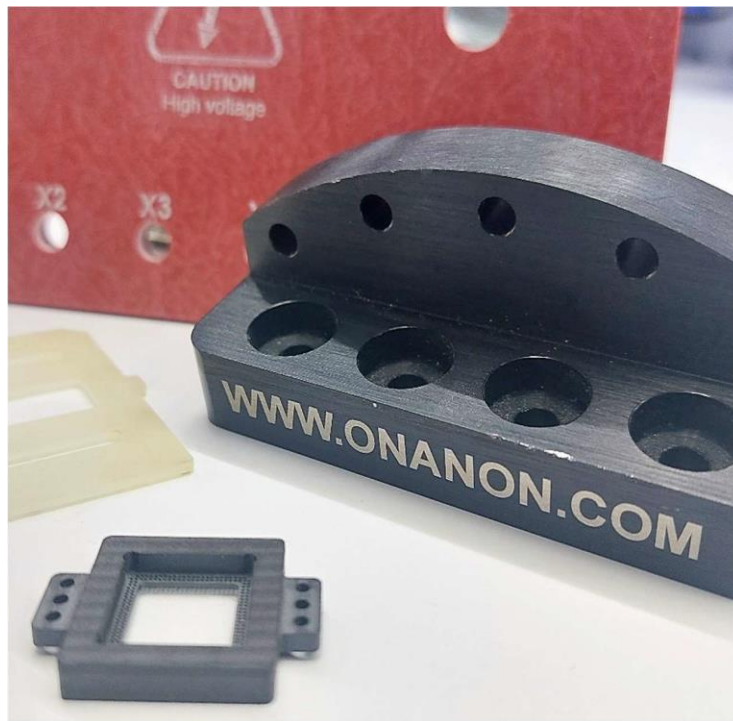
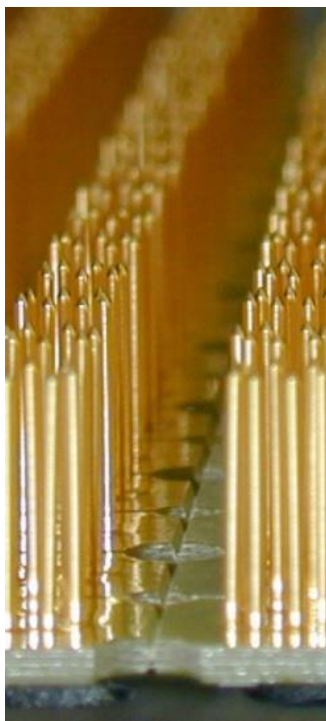

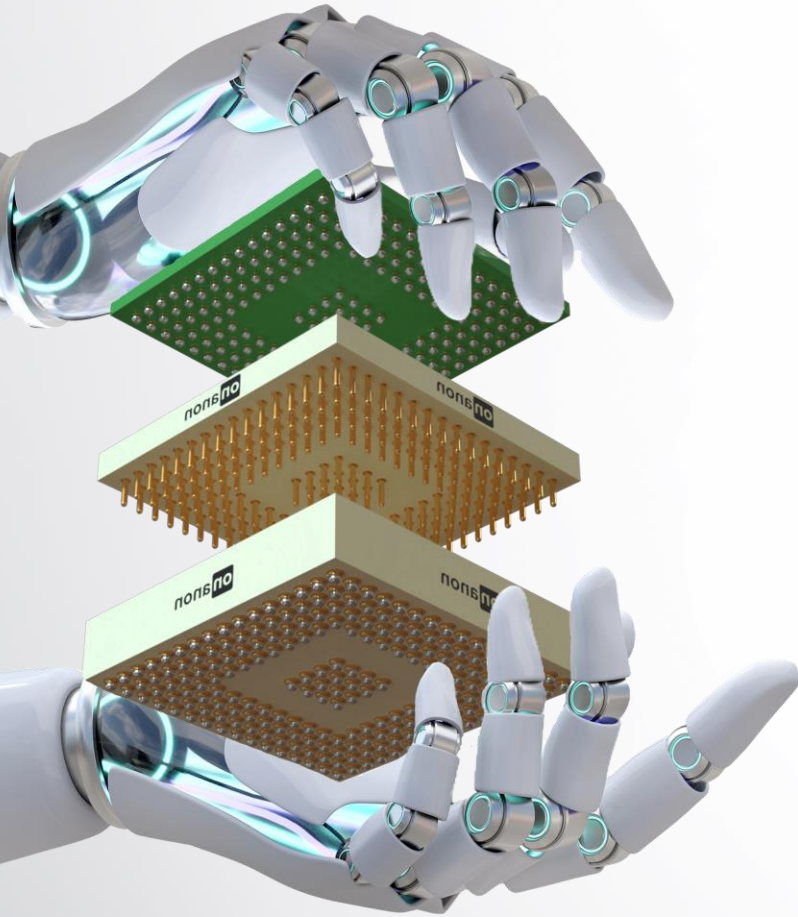

**THE  
CAN DO  
COMPANY**



**onanon.com  
(408) 262-8990**

**2026 Edition**

**720 S Milpitas Blvd, Milpitas, CA 95035**